

Signal converter FU210 / IV210 / ZU210

Frequency (FU210)
Pulse counter (ZU210)
SSI absolute value (IV210)



Analog (current / voltage)
Serial (RS232 / RS485)

Product features:

- Multifunctional unit with several operating modes for incremental encoders or SSI absolute encoders
- For incremental encoders:
 - Operating modes as frequency converter or position transducer (pulse counter)
 - Universal incremental inputs (HTL/TTL/RS422) for NPN/PNP/NAMUR encoders and sensors
 - Functions such as linkages (eg. A+B), scaling, filters, start-up bridging, ...
 - Input frequencies up to 1 MHz
- For SSI absolute encoders:
 - Master or Slave operation with clock frequencies up to 1 MHz
 - For single turn and multi turn encoders with SSI formats from 10 ... 32 Bit
 - Functions such as bit suppression, round-loop function, scaling, ...
- 16 bit analog output, configurable for voltage or current operation
- RS232/RS485-interface for configuration and serial readout
- Extremely short conversion times
- Linearization with 24 control points
- Auxiliary voltage output 5 and 24VDC for encoder supply
- Numerous connection options via 6 control inputs and 6 control outputs
- Compact rail housing to EN60715
- Easy parameterization via user interface OS 6.0 (Freeware)

Version:	Description:
ZU210_01a_oi/tgo/April 19	First Version

Legal notices::
<p>All contents included in this manual are protected by the terms of use and copyrights of motrona GmbH. Any reproduction, modification, usage or publication in other electronic and printed media as well as in the internet requires prior written authorization by motrona GmbH.</p>

Table of Contents

1. Safety Instructions and Responsibility.....	4
1.1 General Safety Instructions.....	4
1.2 Use according to the intended purpose.....	4
1.3 Installation.....	5
1.4 Cleaning, Maintenance and Service Notes.....	5
2. Introduction.....	6
2.1. Operating Mode.....	6
2.2. Function diagram.....	6
2.3. Power – LED / Error messages.....	7
3. Electrical Connections.....	8
3.1 DC Power Supply (X1).....	8
3.1. Hilfsspannungs-Ausgang (X2).....	8
3.2. Incremental encoder input (X2).....	9
3.3. Absolute encoder input (X2).....	11
3.4 Control Inputs (X5).....	13
3.4. Analog output (X4).....	14
3.5. Serial interface (X3).....	15
3.6. Control outputs (X6).....	16
4. Parameter / Overview-Menu Structure.....	17
4.1. General Menu.....	19
4.2. Mode Frequency.....	21
4.3. Mode Counter.....	24
4.4. Mode SSI.....	25
4.6. Preselection Values.....	27
4.7. Preselection 1 Menu.....	28
4.8. Preselection 2 Menu.....	31
4.9. Preselection 3 Menu.....	32
4.10. Preselection 4 Menu.....	33
4.11. Preselection 5 Menu.....	34
4.12. Preselection 6 Menu.....	35
4.13. Serial Menu.....	36
4.14. Analog Menu.....	38
4.15. Command Menu.....	39
4.16. Linearization Menu.....	41
5. Appendix.....	42
6.1. Data readout via serial interface.....	42
6.2. Modbus RTU Interface.....	43
6.2.1 Parameter setting.....	43
6.2.2 Modbus Communication.....	44
6.2.3 Diagnose.....	46
6.2. Parameter / serial codes.....	47
6.3. Linearization.....	52
6.4. Reading SSI-Value.....	54
6.5. Internal processing and calculation of SSI data.....	55
6.6. Dimensions.....	58
6.5. Technical Specifications:.....	59

1. Safety Instructions and Responsibility

1.1 General Safety Instructions

This operation manual is a significant component of the unit and includes important rules and hints about the installation, function and usage. Non-observance can result in damage and/or impairment of the functions to the unit or the machine or even in injury to persons using the equipment!

Please read the following instructions carefully before operating the device and observe all safety and warning instructions! Keep the manual for later use.

A pertinent qualification of the respective staff is a fundamental requirement in order to use these manual. The unit must be installed, connected and put into operation by a qualified electrician.

Liability exclusion: The manufacturer is not liable for personal injury and/or damage to property and for consequential damage, due to incorrect handling, installation and operation. Further claims, due to errors in the operation manual as well as misinterpretations are excluded from liability.

In addition the manufacturer reserves the right to modify the hardware, software or operation manual at any time and without prior notice. Therefore, there might be minor differences between the unit and the descriptions in operation manual.

The raiser respectively positioner is exclusively responsible for the safety of the system and equipment where the unit will be integrated.

During installation or maintenance all general and also all country- and application-specific safety rules and standards must be observed.

If the device is used in processes, where a failure or faulty operation could damage the system or injure persons, appropriate precautions to avoid such consequences must be taken.

1.2 Use according to the intended purpose

The unit is intended exclusively for use in industrial machines, constructions and systems. Non-conforming usage does not correspond to the provisions and lies within the sole responsibility of the user. The manufacturer is not liable for damages which have arisen through unsuitable and improper use.

Please note that device may only be installed in proper form and used in a technically perfect condition (in accordance to the Technical Specifications). The device is not suitable for operation in explosion-proof areas or areas which are excluded by the EN 61010-1 standard.

1.3 Installation

The device is only allowed to be installed and operated within the permissible temperature range. Please ensure an adequate ventilation and avoid all direct contact between the device and hot or aggressive gases and liquids.

Before installation or maintenance, the unit must be disconnected from all voltage-sources. Further it must be ensured that no danger can arise by touching the disconnected voltage-sources.

Devices which are supplied by AC-voltages must be connected exclusively by switches, respectively circuit-breakers with the low voltage network. The switch or circuit-breaker must be placed as near as possible to the device and further indicated as separator.

Incoming as well as outgoing wires and wires for extra low voltages (ELV) must be separated from dangerous electrical cables (SELV circuits) by using a double resp. increased isolation.

All selected wires and isolations must be conform to the provided voltage- and temperature-ranges. Further all country- and application-specific standards, which are relevant for structure, form and quality of the wires, must be ensured. Indications about the permissible wire cross-sections for wiring are described in the Technical Specifications.

Before first start-up it must be ensured that all connections and wires are firmly seated and secured in the screw terminals. All (inclusively unused) terminals must be fastened by turning the relevant screws clockwise up to the stop.

Overvoltages at the connections must be limited to values in accordance to the overvoltage category II.

For placement, wiring, environmental conditions as well as shielding and earthing/grounding of the supply lines the general standards of industrial automation industry and the specific shielding instructions of the manufacturer are valid. Please find all respective hints and rules on www.motrona.com/en/support --> "[General EMC Rules for Wiring, Screening and Earthing]".

1.4 Cleaning, Maintenance and Service Notes

To clean the front of the unit please use only a slightly damp (not wet!), soft cloth. For the rear no cleaning is necessary. For an unscheduled, individual cleaning of the rear the maintenance staff or assembler is self-responsible.

During normal operation no maintenance is necessary. In case of unexpected problems, failures or malfunctions the device must be shipped for back to the manufacturer for checking, adjustment and reparation (if necessary). Unauthorized opening and repairing can have negative effects or failures to the protection-measures of the unit.

2. Introduction

The device is designed as a signal converter with control inputs and outputs. Its extensive functions make it universally applicable.

2.1. Operating Mode

Basically all functions have to be configured in the parameter menu. The device can be used in the following operating modes:

- Operation as frequency converter for incremental input signals (replaces FU252)
- Operation as position transducer / counter for incremental input signals (replaces ZU252)
- Operation as absolute value converter for SSI signals (replaces IV251)

2.2. Function diagram

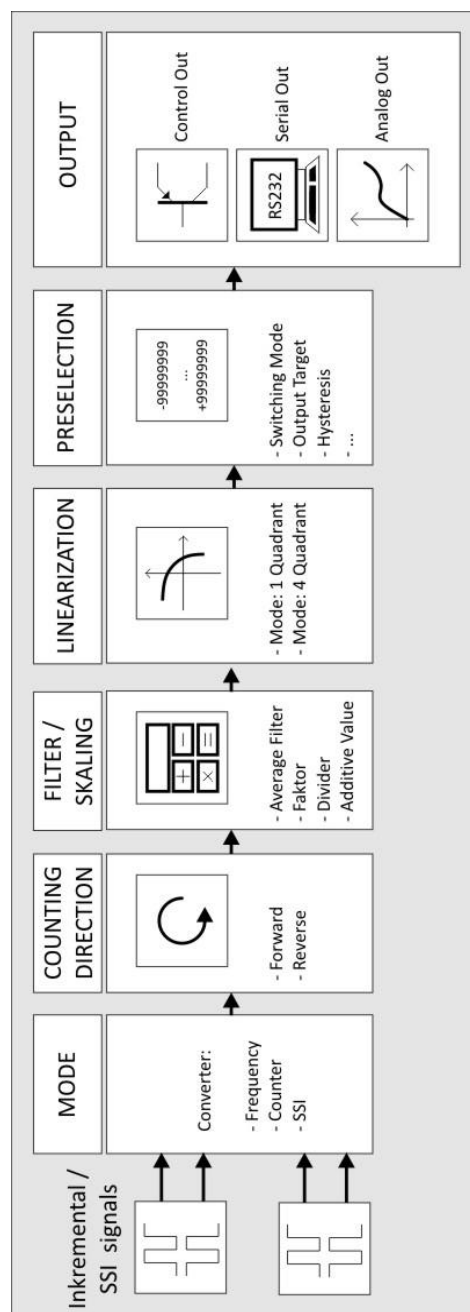

2.3. Power – LED / Error messages

The device has a green LED on its front foil. This lights up permanently as soon as the supply voltage of the device has been applied. If an error occurs, the LED flashes at 1 Hz. If the error no longer exists, the LED will automatically light up again permanently.

The exact error can be read out via the serial interface via the user interface (OS 6.0).

(→ Variable: Error_Status, Code: "; 3")

The individual error codes are explained below:

Errorcode: (Error_Status)	Error identification:	Error description:
0x00000001	Maximum Value	Measured value is greater than 99999999
0x00000002	Minimum Value	Measured value is less than -99999999
0x00000004	SSI Encoder Error	SSI error bit set

3. Electrical Connections

The terminal screws should be tightened with a slotted screwdriver (blade width 2mm).

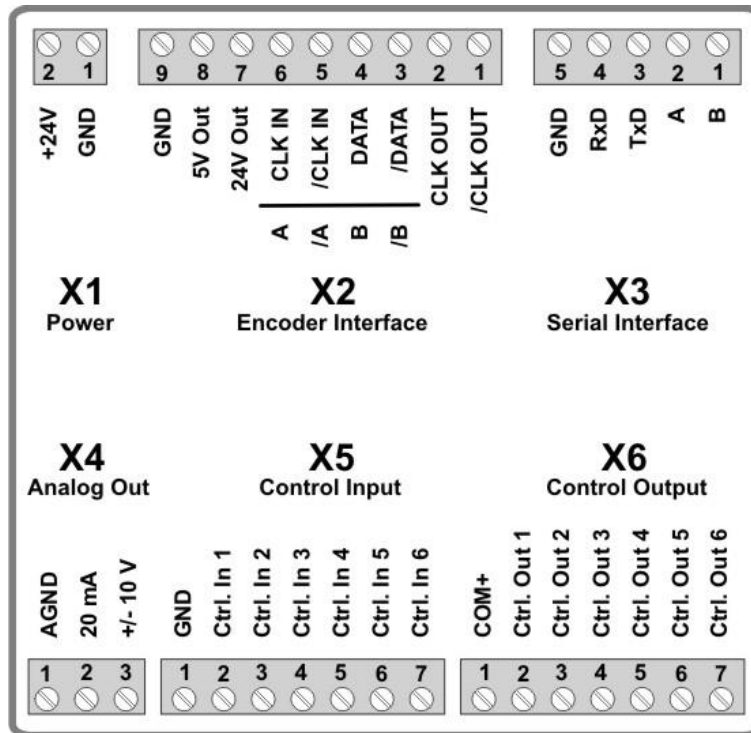

3.1 DC Power Supply (X1)

The unit accepts DC supply from 18 to 30 V at the terminals X1 1 and 2. The power consumption depends on the level of the supply voltage with approx. 50 mA and the additional current required at the Auxiliary Voltage Output.

All GND terminals are internally interconnected.

3.1.1. Hilfsspannungs-Ausgang (X2)

Two auxiliary voltages (24 VDC and 5 VDC) are available as encoder / sensor supply at terminal X2 pins 7, 8 and 9. The 24 VDC output voltage depends on the device supply (see technical data).

3.2. Incremental encoder input (X2)

Terminal X2 pins 3, 4, 5 and 6 provide a connection for various incremental signals.

RS422

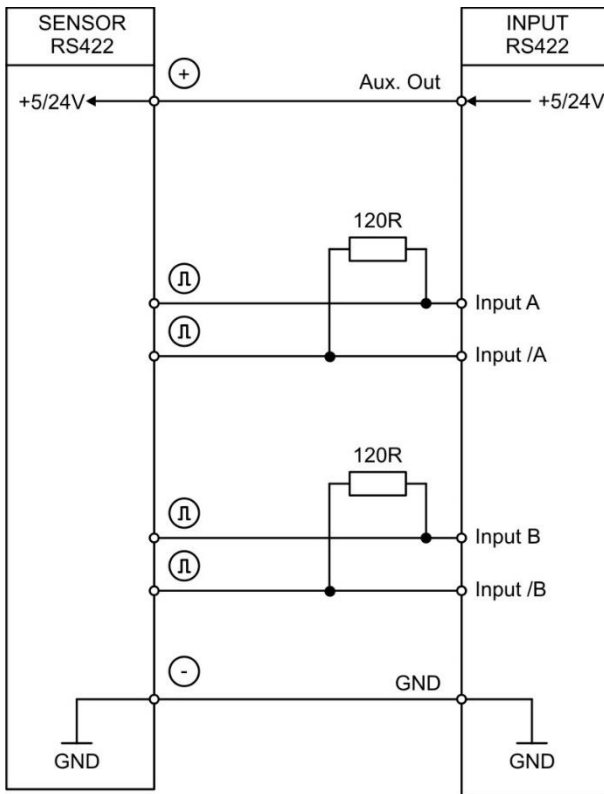

HTL DIFFERENTIAL

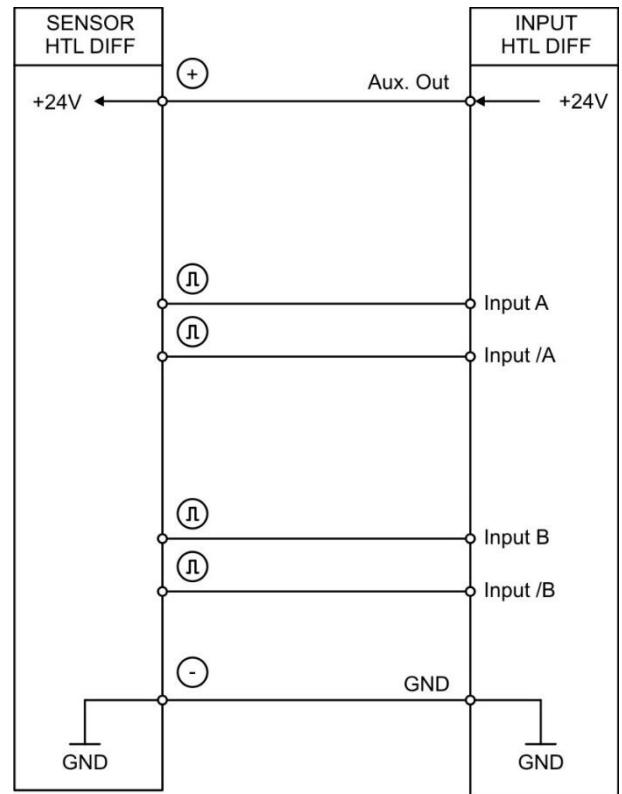

HTL PNP

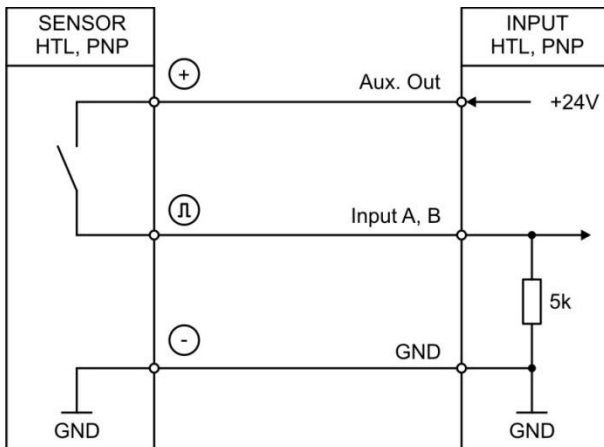

HTL NPN

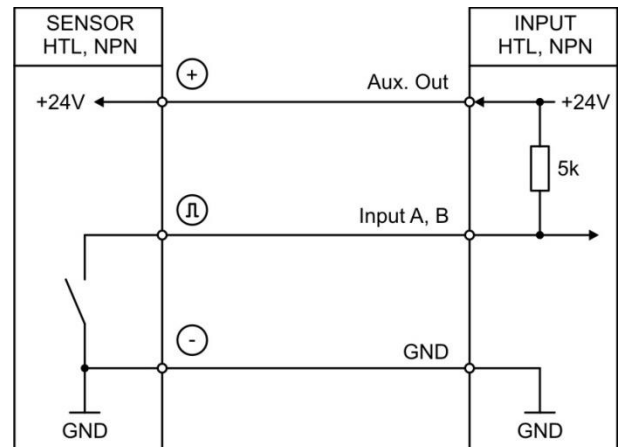

Continuation „Incremental encoder input (X2)“:

HTL NPN (NAMUR)

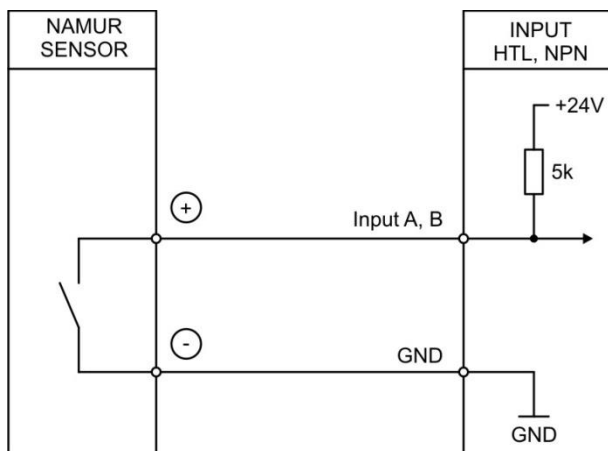

TTL (PNP)

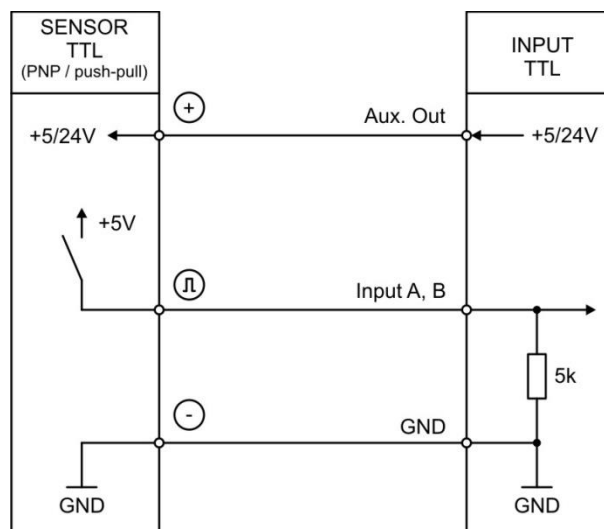

Unconnected PNP inputs are always “LOW” and unconnected NPN inputs are always “HIGH”. All inputs are designed to receive impulses from electrical impulse sources.

Notice for mechanical switching contacts:

When exceptionally mechanical contacts are used, please connect an external capacitor between GND (-) and the corresponding input (+). A capacity of 10 μF will reduce the input frequency to 20 Hz and miscounting due to contact bouncing will be eliminated.

3.3. Absolute encoder input (X2)

At terminal X2 pin 1, 2, 3, 4 the SSI connection for the MODE MASTER is available.

At terminal X2 pin 3, 4, 5, 6 the SSI connection for the MODE SLAVE is available.

Connection for **MODE Master**:

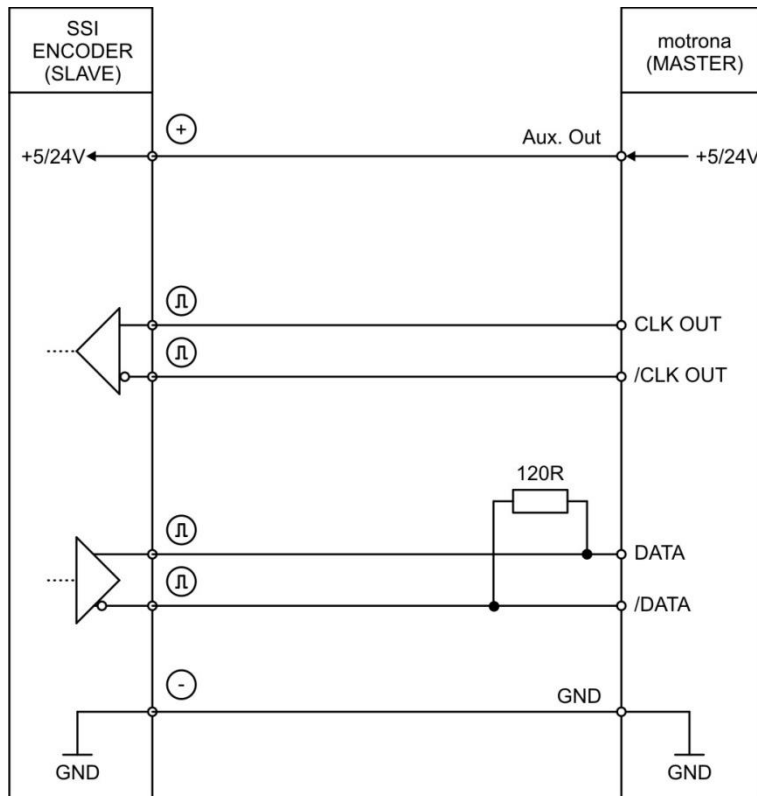

Continuation „Absolute encoder input (X2)“:

Connection for **MODE Slave**:

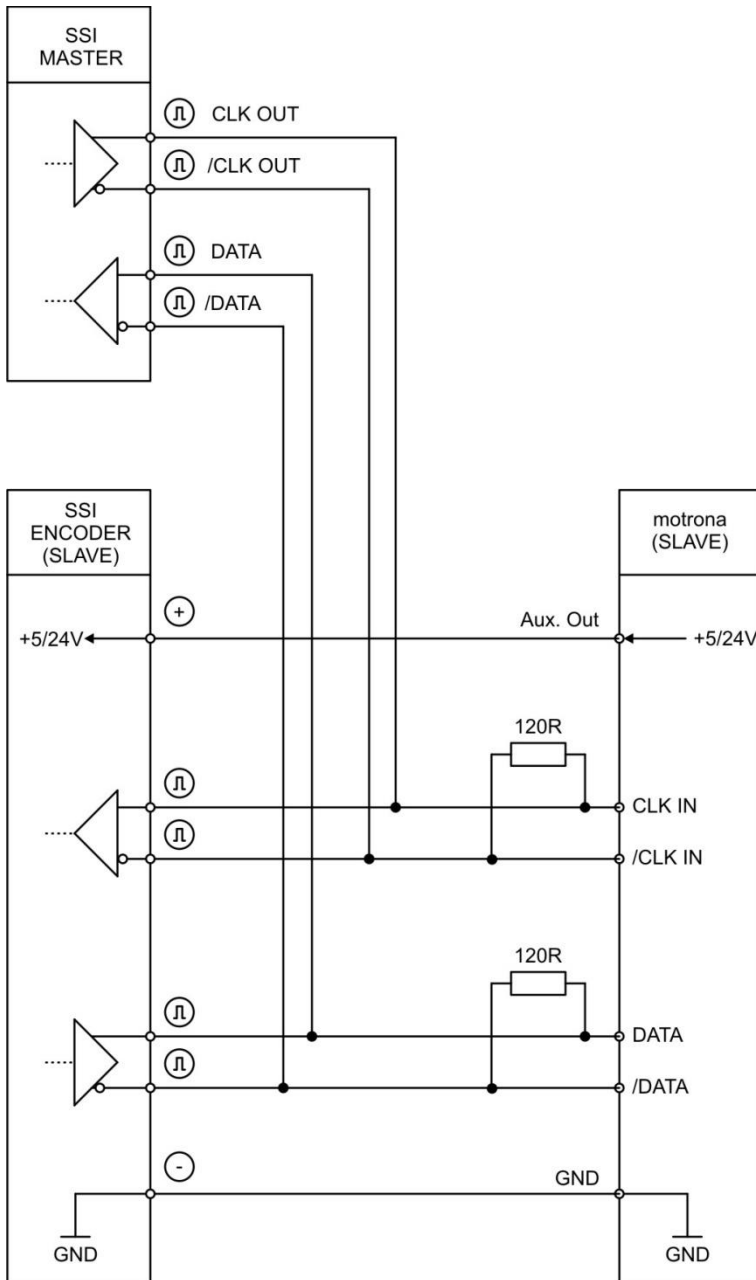

3.4 Control Inputs (X5)

At terminal X5 pins 2,3,4,5,6 and 7 there are six control inputs with HTL PNP characteristic available. Control Input 1 (Ctrl. In 1) to Control Input 5 (Ctrl. In 5) are freely configurable in the COMMAND MENU and are used for functions to be triggered externally. eg. for releasing the latching, resetting the measurement result or for teaching the preset values or the analog output.

Control input 6 (Ctrl. In 6) is used exclusively for resetting the device parameters to the "default" values. Thus, it is not freely configurable.



Note: With an HTL pulse (rising edge) on Ctrl. In 6, the device is reset to the factory settings.

Wiring of the control inputs:

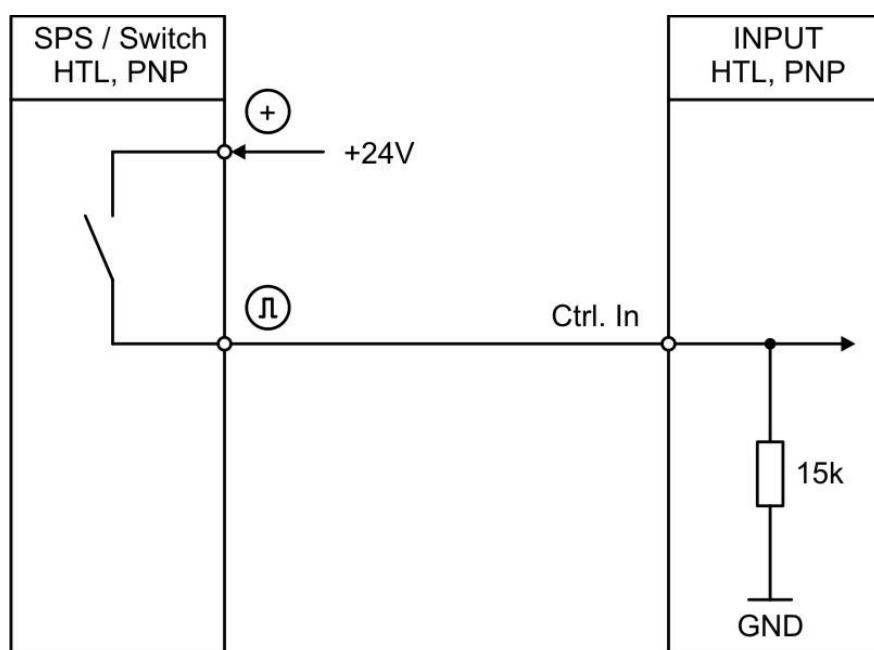

Unconnected control inputs are always "LOW".

All inputs are designed to receive impulses from an electronic impulse source.

Notice for mechanical switching contacts:

When exceptionally mechanical contacts are used, please connect an external capacitor between GND (-) and the corresponding input (+). A capacity of 10 μF will reduce the input frequency to 20 Hz and miscounting due to contact bouncing will be eliminated.

3.4. Analog output (X4)

A 16 bit analog output is available at terminal X4 pin 1, 2 and 3.
This output can be configured and scaled in the ANALOG MENU.

The following configuration is possible:

- Voltage output: -10 ... +10 V
- Current output: 0 ... 20 mA
- Current output: 4 ... 20 mA

The analog output is proportional to the display value and is referenced to potential AGND.
AGND and GND are internally interconnected.



Important:

A parallel operation with voltage and current output at the analog output is not allowed.

3.5. Serial interface (X3)

A serial interface (RS232 or RS485) is available at terminal X3. This interface can be configured in the SERIAL MENU.

The serial interface RS232 or RS485 can be used:

- for easy setup and commissioning of the units
- to modify settings and parameters during operation
- to read out internal states and actual measuring values by PC or PLC

The following drawing shows the connection to a PC by using a standard Sub-D-9 connector:

Connection of the **RS232** interface:

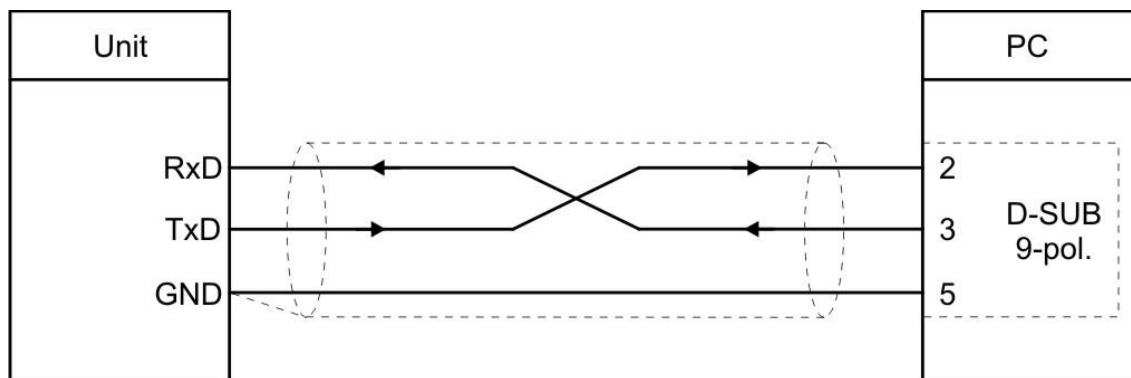

Connection of the **RS485**-interface:

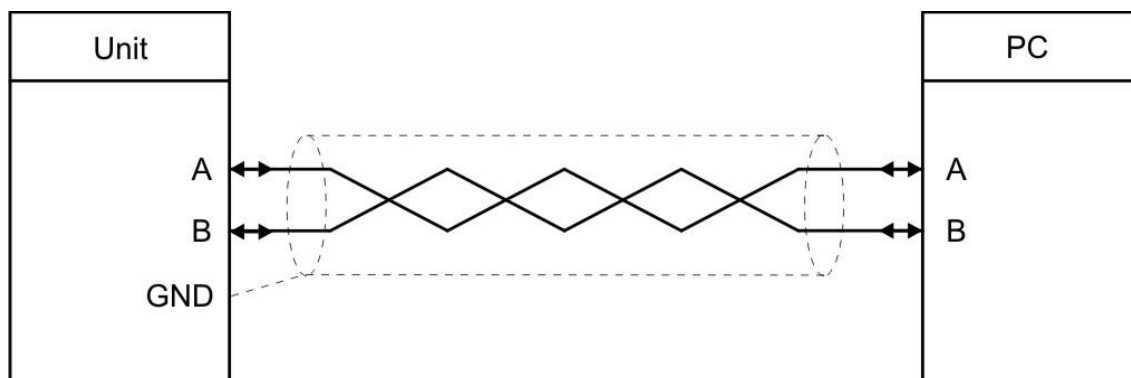

Important: Parallel operation of RS232 and RS485 is not allowed!

3.6. Control outputs (X6)

Six control outputs are available at terminal X6 pin 2, 3, 4, 5, 6 and 7.

Switching conditions can be set in the PRESELECTION MENU. The output Ctrl. Out1 – 6 are fast PNP outputs with a switching capability of 5 – 30 Volt / 200 mA per channel.

The switching voltage of the outputs must be applied to input terminal X6 pin 1 (COM+).

In case of switching inductive loads it is advisable to use external filtering of the coils.

Wiring of the **control-outputs**:

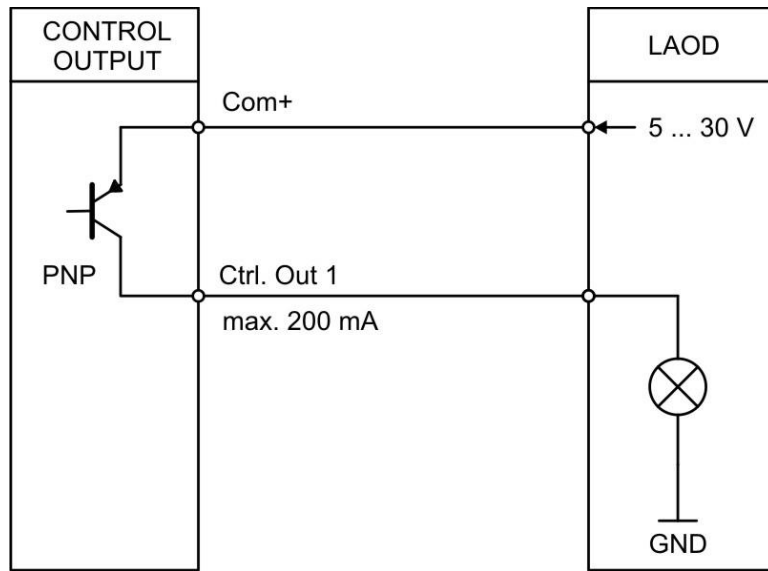

4. Parameter / Overview-Menu Structure

This section provides an overview of the menus and their parameters. The menu names are printed bold and the associated parameters are listed under the menu name.

Menu / Parameter	Menu / Parameter
GENERAL MENU	MODE SSI
MODE	SSI MODE
ENCODER PROPERTIES	ENCODER RESOLUTION
ENCODER DIRECTION	DATA FORMAT
AVERAGE FILTER	BAUD RATE
FACTOR	SSI ZERO
DIVIDER	HIGH BIT
ADDITIVE VALUE	LOW BIT
LINEARIZATION MODE	SSI OFFSET
BACKUP MEMORY	ROUND LOOP VALUE
FACTORY SETTINGS	SAMPLING TIME (S)
	ERROR BIT
	ERROR POLARITY
MODE FREQUENCY	PRESELECTION VALUES
FREQUENCY MODE	PRESELECTION 1
FREQUENCY BASE	PRESELECTION 2
SAMPLING TIME 1 (S)	PRESELECTION 3
WAIT TIME 1(S)	PRESELECTION 4
STANDSTILL TIME 1 (S)	PRESELECTION 5
SAMPLING TIME 2 (S)	PRESELECTION 6
WAIT TIME 2(S)	
MODE COUNTER	PRESELECTION 1 MENU
COUNT MODE	MODE 1
FACTOR A	HYSTERESIS 1
SET VALUE A	PULSE TIME 1 (S)
FACTOR B	OUTPUT TARGET 1
SET VALUE B	OUTPUT POLARITY 1
ROUND LOOP VALUE	OUTPUT LOCK 1
	START UP DELAY 1 (S)
	PRESELECTION 2 MENU
	MODE 2
	HYSTERESIS 2
	PULSE TIME 2 (S)
	OUTPUT TARGET 2
	OUTPUT POLARITY 2
	OUTPUT LOCK 2
	START UP DELAY 2 (S)

Continuation „Parameter / menu structure“:

Menu / Parameter
PRESELECTION 3 MENU
MODE 3 HYSTERESIS 3 PULSE TIME 3 (S) OUTPUT TARGET 3 OUTPUT POLARITY 3 OUTPUT LOCK 3 START UP DELAY 3 (S)
PRESELECTION 4 MENU
MODE 4 HYSTERESIS 4 PULSE TIME 4 (S) OUTPUT TARGET 4 OUTPUT POLARITY 4 (S) OUTPUT LOCK 4 START UP DELAY 4 (S)
PRESELECTION 5 MENU
MODE 5 HYSTERESIS 5 PULSE TIME 5 (S) OUTPUT TARGET 5 OUTPUT POLARITY 5 OUTPUT LOCK 5 START UP DELAY 5 (S)
PRESELECTION 6 MENU
MODE 6 HYSTERESIS 6 PULSE TIME 6 (S) OUTPUT TARGET 6 OUTPUT POLARITY 6 OUTPUT LOCK 6 START UP DELAY 6 (S)
SERIAL MENU
UNIT NUMBER SERIAL BAUD RATE SERIAL FORMAT SERIAL INIT SERIAL PROTOCOL SERIAL TIMER (S) SERIAL VALUE MODBUS

Menu / Parameter
ANALOG MENU
ANALOG FORMAT ANALOG START ANALOG END ANALOG GAIN (%) ANALOG OFFSET (%)
COMMAND MENU
INPUT 1 ACTION INPUT 1 CONFIG INPUT 2 ACTION INPUT 2 CONFIG INPUT 3 ACTION INPUT 3 CONFIG INPUT 4 ACTION INPUT 4 CONFIG INPUT 5 ACTION INPUT 5 CONFIG INPUT 6 ACTION (FACTORY SETTINGS) INPUT 6 CONFIG (RISING EDGE)
LINEARISATION MENU
P1(X) P1(Y) P2(X) P2(Y) P23(X) P23(Y) P24(X) P24(Y)

4.1. General Menu

MODE		
This parameter specifies the selected measuring function.		
0	NOT DEFINED	Operating mode: Not defined, modulation and measurement results are zero
1	FREQUENCY	Operating mode: Frequency converter, incremental signals (replaces FU252)
2	COUNTER	Operating mode: Counter, incremental signals (replaces ZU252)
3	SSI	Operating mode: Absolute value converter, SSI signals (replaces IV251)

ENCODER PROPERTIES		
This parameter determines the characteristics of the incremental input.		
0	RS422	RS422
1	HTL DIFFERENTIAL	HTL differential
2	HTL PNP	PNP (switch to +)
3	HTL NPN	NPN (switch to -)
4	TTL PNP	TTL PNP (switch to +)

ENCODER DIRECTION		
This parameter reverses the counting or traversing direction.		
0	FORWARD	Forward
1	REVERSE	Reverse

AVERAGE FILTER		
Selectable average or filter function to avoid measuring fluctuations by unstable frequencies. At setting 1 to 4 a floating average calculation is performed.		
	0	No average value will be created
	1	2 numbers of floating average cycles
	2	4 numbers of floating average cycles
	3	8 numbers of floating average cycles
	4	16 numbers of floating average cycles

FACTOR		
This parameter defines the factor with which the measurement result is multiplied.		
	-99999999	Smallest value
	1	Default value
	99999999	Highest value

DIVIDER		
This parameter defines the divisor with which the measurement result is divided.		
	-99999999	Smallest value
	1	Default value
	99999999	Highest value

Continuation „General Menu“:

ADDITIVE VALUE		
This parameter defines an additive constant, which is added to the measurement result.		
	-99999999	Smallest value
	0	Default value
	99999999	Highest value

LINEARIZATION MODE		
This parameter defines the linearization function. Observe notes in the appendix!		
0	OFF	No linearization
1	1 QUADRANT	Linearization in the 1. quadrant
2	4 QUADRANT	Linearization in all 4 quadrants

BACK UP MEMORY		
0	NO	No back up memory –up by power failure
1	YES	Back up memory is active. Saves the actual value of the counter readings in case of power failure and switched on mode "Counter".

FACTORY SETTINGS		
0	NO	No default values are loaded
1	YES	Load default values of all parameters (grey marked default values)

4.2. Mode Frequency

In this menu the operation is defined as a frequency converter (incremental signals). Depending on the selected operating mode, only channel A or both channels (channel A and channel B) are active.

FREQUENCY MODE		
This parameter determines which frequency measurement mode is desired.		
0	A ONLY	Single-channel frequency measurement (only for channel A)
1	RATIO	Frequency ratio of both channels (channel B / channel A). <u>Note:</u> Interpretation of the result with 4 decimal places in the format +/- x.xxxx
2	PERCENT	Percent deviation from channel B to channel A. <u>Note:</u> Interpretation of the result with 2 decimal places in the format +/- xxx.xx %
3	A + B	Frequency addition of both channels (channel A + channel B)
4	A - B	Frequency subtraction of both channels (channel A - channel B)
5	A/B x 90°	Frequency measurement with A / B x 90° signal. (Forward / reverse direction of rotation detection)

FREQUENCY BASE		
Setting the desired basis for the frequency measurement (resolution).		
	0	1 Hz (Interpretation of the result in the format: xxxxxxxx Hz)
	1	1/10 Hz (Interpretation of the result in the format: xxxxxxx.x Hz)
	2	1/100 Hz (Interpretation of the result in the format: xxxxxx.xx Hz)
	3	1/1000 Hz (Interpretation of the result in the format: xxxxx.xxx Hz)

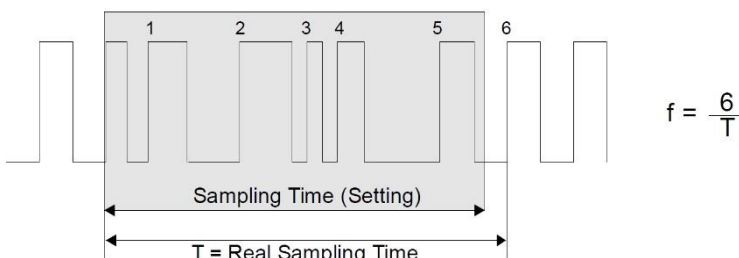
SAMPLING TIME 1 (S)		
The set value corresponds to the minimum measuring time (for channel A) in seconds.		
The sampling time serves as a filter at irregular frequencies.		
This parameter directly influences the reaction time of the device.		
	0,001	Shortest Sampling time
	0,1	Default value
	9,999	Longest Sampling time
 <p style="text-align: right;">$f = \frac{6}{T}$</p>		

Continuation „Mode Frequency“:

WAIT TIME 1 (S)
 This parameter defines the period time of the lowest frequency, accordingly the time between two rising signal edges on channel A detecting frequency 0 Hz. Frequencies with a period time higher than the set "WAIT TIME 1" will be detected as frequency = 0 Hz.

0,01	Frequency = 0 Hz, for frequencies below 100 Hz
1,00	Default value
79,99	Frequency = 0 Hz, for frequencies below 0,01 Hz

STANDSTILL TIME 1 (S)
 This parameter defines the time setting for standstill definition. A time of xx.xx seconds after detection "Frequency = 0 Hz " at channel A the unit signals "standstill" and reactivates the start-up-delays. Stand still detection can be set in PRESELECTION MENU.

0,01	Shortest time in seconds
...	
99,99	Largest time in seconds

SAMPLING TIME 2 (S)
 The set value corresponds to the minimum measuring time (for channel B) in seconds. The sampling time serves as a filter at irregular frequencies. This parameter directly influences the reaction time of the device

0,001	Shortest Sampling time
0,1	Default value
9,999	Longest Sampling time

Continuation „Mode Frequency“:

WAIT TIME 2 (S)

This parameter defines the period time of the lowest frequency, accordingly the time between two rising signal edges on channel B detecting frequency 0 Hz. Frequencies with a period time higher than the set "WAIT TIME 2" will be detected as frequency = 0 Hz.

0,01	Frequency = 0 Hz, for frequencies below 100 Hz
1,00	Default value
79,99	Frequency = 0 Hz, for frequencies below 0,01 Hz

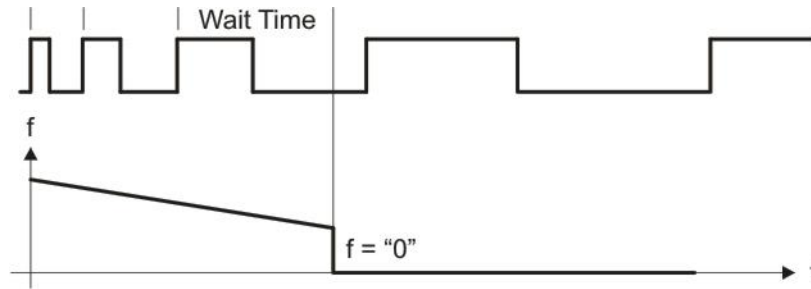

4.3. Mode Counter

In this menu, the operation is defined as a position transducer for incremental signals (pulse, sum, difference, up or down counter). Input A and B are active.

COUNT MODE		
This parameter defines the counter operation.		
0	A SINGLE	Input A is a counting input. Input B defines the counting direction: „LOW“ = forward „HIGH“ = reverse
1	A + B	Sum counter: Impulses at A + Impulses at B
2	A - B	Differential counter: Impulses at A – impulses at B
3	A/B 90 x1	Quadrature counter: Impulses A, B with edge counting x1
4	A/B 90 x2	Quadrature counter: Impulses A, B with edge counting x2
5	A/B 90 x4	Quadrature counter: Impulses A, B with edge counting x4

FACTOR A		
Scaling factor for input A.		
For example: A setting of factor 1.23456 and 100000 input pulses will result in a value of 123456 for input A.		
	0,00001	Smallest value
	1	Default value
	99,99999	Highest value

SET VALUE A		
With a "RESET / SET COUNTER A" command (via control input), the counter of input A is set to this value.		
	-99999999	Smallest value
	0	Default value
	+99999999	Highest value

FACTOR B		
Scaling factor for input B.		
For example: A setting of factor 1.23456 and 100000 input pulses will result in a value of 123456 for input B.		
	0,00001	Smallest value
	1	Default value
	99,99999	Highest value

SET VALUE B		
With a "RESET / SET COUNTER B" command (via control input), the counter of input B is set to this value.		
	-99999999	Smallest value
	0	Default value
	+99999999	Highest value

ROUND LOOP VALUE		
Defines the number of encoder steps if a round-loop function is desired. (Only for COUNT MODE: A SINGLE and A / B x 90)		
	0	Round-loop function is turned off.
	...	
	99999999	Number of steps for the round-loop function.

4.4. Mode SSI

In this menu the operation is defined as absolute value converter (SSI signals).

SSI MODE		
SSI Setting of the operating mode: Maser or Slave		
Depending on the SSI MODE, different terminals must be used for the SSI CLK!		
(Mode Master: Terminal X2 - Pin 1 and 2 / Mode Slave: Terminal X2 - Pin 5 and 6)		
0	MASTER	Master-Mode: Clock for SSI encoder comes from the device
1	SLAVE	Slave-Mode: Clock for SSI encoder comes from the external master.

ENCODER RESOLUTION		
Resolution of the SSI encoder (total number of bits)		
	10	Smallest value
	25	Default value
	32	Highest value

DATA FORMAT		
Setting the SSI code (binary or gray)		
0	GRAY CODE	SSI-Code Gray
1	BINARY CODE	SSI-Code Binär

BAUD RATE		
Clock frequency of SSI telegrams		
0	2 MHZ	N.A.
1	1.5 MHZ	N.A.
2	1 MHZ	Clock frequency 1 MHz
3	500 KHZ	Clock frequency 500 kHz
4	250 KHZ	Clock frequency 250 kHz
5	100 KHZ	Clock frequency 100 kHz

SSI ZERO		
In the case of a "ZERO POSITION" command (via control input), the current SSI position of the encoder is transferred to the "SSI ZERO" parameter and the actual encoder zero point is shifted accordingly. (Encoder zero offset)		
	0	Smallest value
	...	
	999999999	Highest value

HIGH BIT (for bit blanking)		
Defines the highest evaluated bit (MSB) for bit blanking.		
If all bits should be evaluated, HIGH BIT must be set to the given total number of bit.		
	01	Smallest value
	25	Default value
	32	Highest value

Continuation „Mode SSI“:

LOW BIT (for bit blanking)		
Defines the lowest evaluated bit (MSB) for bit blanking. If all bits should be evaluated, LOW BIT must be set to 01.		
	01	Smallest value
	...	
	32	Highest value

SSI OFFSET		
In the case of a „RESET/SET VALUE“ command (via control input or PC user interface) the not yet scaled, currently acquired position value (after bit suppression and possibly performed encoder zero offset) is transferred to the "SSI OFFSET" parameter and the display zeroed. From the new display zero point, you can now move in positive and negative direction, depending on the direction of rotation. (Display offset)		
	0	Smallest value
	...	
	99999999	Highest value

ROUND LOOP VALUE		
Defines the number of encoder steps when a round-loop function is desired.		
	0	Round-loop function is turned off.
	...	
	99999999	Number of steps for the round-loop function.

SAMPLING TIME (S)		
Determines the read cycle for the SSI signal in the Master MODE.		
	0.001	Minimum measurement time in seconds
	0.010	Default value
	9.999	Maximum measurement time in seconds

ERROR BIT		
Defines the encoder monitoring and the error bit		
	0	No error bit available. Review on connected sensor is turned off.
	...	
	32	Position of the error bits to be evaluated Review on connected sensor is turned on.

ERROR POLARITY		
Defined the polarity of the error bit in the case of an error		
	0	Bit is low in the case of an error
	1	Bit is high in the case of an error

	Note: SSI value processing see appendix (chapter 6.5 and 6.6)
---	--

4.6. Preselection Values

This menu is used to set the preselection values of the switching points.

PRESELECTION 1		
Preselection / switching point 1		
	-99999999	Smallest value
	1000	Default value
	+99999999	Highest value

PRESELECTION 2		
Preselection / switching point 2		
	-99999999	Smallest value
	2000	Default value
	+99999999	Highest value

PRESELECTION 3		
Preselection / switching point 3		
	-99999999	Smallest value
	3000	Default value
	+99999999	Highest value

PRESELECTION 4		
Preselection / switching point 4		
	-99999999	Smallest value
	4000	Default value
	+99999999	Highest value

PRESELECTION 5		
Preselection / switching point 5		
	-99999999	Smallest value
	5000	Default value
	+99999999	Highest value

PRESELECTION 6		
Preselection / switching point 6		
	-99999999	Smallest value
	6000	Default value
	+99999999	Highest value

4.7. Preselection 1 Menu

MODE 1		
Switching conditions for preselection 1. Output switches under the following conditions:		
0	$ \text{RESULT} \geq \text{PRES} $	Absolute value of the display value is greater or equal absolute value of PRESELECTION 1 With HYSTERESIS 1 not equal 0 the following switching condition is applied: Display value \geq PRESELECTION 1 \rightarrow ON, Display value $<$ PRESELECTION 1 – HYSTERESIS 1 \rightarrow OFF
1	$ \text{RESULT} \leq \text{PRES} $	Absolute value of the display value is less or equal absolute value of PRESELECTION 1 (start-up suppression (START UP DELAY) is advisable) With HYSTERESIS 1 not equal 0 the following switching condition is applied: Display value \leq PRESELECTION 1 \rightarrow ON, Display value $>$ PRESELECTION 1 + HYSTERESIS 1 \rightarrow OFF
2	$ \text{RESULT} = \text{PRES} $	Absolute value of the display value is equal absolute value of PRESELECTION 1 A range (Preselection +/- ½ Hysteresis) can be defined and monitored in conjunction with the hysteresis. With HYSTERESIS 1 not equal 0 the following switching condition is applied: Display value $>$ PRESELECTION 1 + ½ HYSTERESIS 1 \rightarrow OFF, Display value $<$ PRESELECTION 1 - ½ HYSTERESIS 1 \rightarrow OFF
3	$\text{RESULT} \geq \text{PRES}$	Display value is greater or equal PRESELECTION 1, e.g. overspeed With HYSTERESIS 1 not equal 0 the following switching condition is applied: Display value \geq PRESELECTION 1 \rightarrow ON, Display value $<$ PRESELECTION 1 – HYSTERESIS 1 \rightarrow OFF
4	$\text{RESULT} \leq \text{PRES}$	Display value is less or equal PRESELECTION 1, e.g. underspeed (start-up suppression (START UP DELAY) is advisable) With HYSTERESIS 1 not equal 0 the following switching condition is applied: Display value \leq PRESELECTION 1 \rightarrow ON, Display value $>$ PRESELECTION 1 + HYSTERESIS 1 \rightarrow OFF
5	$\text{RESULT} = \text{PRES}$	Display value is equal PRESELECTION 1. A range (Preselection +/- ½ Hysteresis) can be defined and monitored in conjunction with the hysteresis. With HYSTERESIS 1 not equal 0 the following switching condition is applied: Display value $>$ PRESELECTION 1 + ½ HYSTERESIS 1 \rightarrow OFF, Display value $<$ PRESELECTION 1 - ½ HYSTERESIS 1 \rightarrow OFF
6	$\text{RESULT} = 0$	Display value is zero (Standstill after STANDSTILL TIME 1(s)), e. g. standstill monitoring, (only in mode FREQUENCY).
7	$\text{RES} \geq \text{PRES-TRAIL}$	Trailing PRESELECTION 1: Display value is greater or equal PRESELECTION 1 – PRESELECTION 4 \rightarrow ON, PRESELECTION 4 is the trailing value from PRESELECTION 1
8	ERROR SET	Error message for device errors.

Continuation „Preselection 1 Menu“:

HYSTERESIS 1		
This parameter defines the switching hysteresis of the switch-off point for preselection 1		
	0	No switching hysteresis
	...	
	99999	Switching hysteresis of 99999

PULSE TIME 1 (S)		
Duration of output pulse for the switching condition of preselection 1		
	0,000	No output pulse (static signal)
	...	
	60,000	Pulse duration of 60 seconds

OUTPUT TARGET 1		
Assignment of an output for the switching condition of preselection 1. If more than one switching condition is assigned to one output, the output is set when at least one switching condition is true		
	0 NO	No assignment
	1 CTRL OUT 1	Switching condition assigned to "Ctrl. Out 1"
	2 CTRL OUT 2	Switching condition assigned to "Ctrl. Out 2"
	3 CTRL OUT 3	Switching condition assigned to "Ctrl. Out 3"
	4 CTRL OUT 4	Switching condition assigned to "Ctrl. Out 4"
	5 CTRL OUT 5	Switching condition assigned to "Ctrl. Out 5"
	6 CTRL OUT 6	Switching condition assigned to "Ctrl. Out 6"

OUTPUT POLARITY 1		
Polarity for the switching condition of preselection 1		
	0 ACTIVE HIGH	Switching condition is true → Active „HIGH“
	1 ACTIVE LOW	Switching condition is true → Active „LOW“

OUTPUT LOCK 1		
Latch for the switching condition of preselection 1		
	0 NO	No latch for preselection
	1 YES	Latch for preselection (command LOCK RELEASE will clear latch)

Continuation „Preselection 1 Menu“:

START UP DELAY 1 (S)

Start-up suppression for the switching condition of preselection 1. Time to start the monitoring function. This adjustment is only valid for the switching condition $|\text{RESULT}| \leq |\text{PRES}|$ or $\text{RESULT} \leq \text{PRES}$ and only for MODE „FREQUENCY“ – Channel A.

START UP DELAY is set to this parameter, when the frequency is detected as 0 Hz. The monitoring function remains deactivated until the set time has elapsed.

With a setting "60.000", the automatic start override is activated. The monitoring function remains deactivated until the preset value / switching point is exceeded for the first time.

	0.000	No start-up suppression
	...	
	59.999	Start-up suppression in seconds
	60.000	Automatic start-up suppression

4.8. Preselection 2 Menu

MODE 2		
Switching conditions for preselection 2., see chapter PRESELECTION 1 MENU (except the trailing value)		
		See chapter PRESELECTION 1 MENU
6	RES>=PRES-TRAIL	Trailing PRESELECTION 2: Display value is greater or equal PRESELECTION 2 – PRESELECTION 5 → ON, PRESELECTION 5 is the trailing value from PRESELECTION 2

HYSTERESIS 2
This parameter defines the switching hysteresis of the switch-off point for preselection 2. See chapter PRESELECTION 1 MENU.

PULSE TIME 2 (S)
Duration of output pulse for the switching condition of preselection 2. See chapter PRESELECTION 1 MENU..

OUTPUT TARGET 2		
Assignment of an output for the switching condition of preselection 2. See chapter PRESELECTION 1 MENU.		
0	NO	No assignment
1	CTRL OUT 1	Switching condition assigned to "Ctrl. Out 1"
2	CTRL OUT 2	Switching condition assigned to "Ctrl. Out 2"
3	CTRL OUT 3	Switching condition assigned to "Ctrl. Out 3"
4	CTRL OUT 4	Switching condition assigned to "Ctrl. Out 4"
5	CTRL OUT 5	Switching condition assigned to "Ctrl. Out 5"
6	CTRL OUT 6	Switching condition assigned to "Ctrl. Out 6"

OUTPUT POLARITY 2
Polarity for the switching condition of preselection 2. See chapter PRESELECTION 1 MENU.

OUTPUT LOCK 2
Latch for the switching condition of preselection 2. See chapter PRESELECTION 1 MENU.

START UP DELAY 2 (S)
Start-up suppression for the switching condition of preselection 2. See chapter PRESELECTION 1 MENU.

4.9. Preselection 3 Menu

MODE 3		
Switching conditions for preselection 3. see chapter PRESELECTION 1 MENU (except the trailing value).		
		See chapter PRESELECTION 1 MENU
6	RES>=PRES-TRAIL	Trailing PRESELECTION 3: Display value is greater or equal PRESELECTION 3 – PRESELECTION 6 → ON, PRESELECTION 6 is the trailing value from PRESELECTION 3

HYSTERESIS 3
This parameter defines the switching hysteresis of the switch-off point for preselection 3. See chapter PRESELECTION 1 MENU.

PULSE TIME 3 (S)
Duration of output pulse for the switching condition of preselection 3. See chapter PRESELECTION 1 MENU.

OUTPUT TARGET 3		
Assignment of an output for the switching condition of preselection 3. See chapter PRESELECTION 1 MENU.		
0	NO	No assignment
1	CTRL OUT 1	Switching condition assigned to "Ctrl. Out 1"
2	CTRL OUT 2	Switching condition assigned to "Ctrl. Out 2"
3	CTRL OUT 3	Switching condition assigned to "Ctrl. Out 3"
4	CTRL OUT 4	Switching condition assigned to "Ctrl. Out 4"
5	CTRL OUT 5	Switching condition assigned to "Ctrl. Out 5"
6	CTRL OUT 6	Switching condition assigned to "Ctrl. Out 6"

OUTPUT POLARITY 3
Polarity for the switching condition of preselection 3. See chapter PRESELECTION 1 MENU.

OUTPUT LOCK 3
Latch for the switching condition of preselection 3. See chapter PRESELECTION 1 MENU.

START UP DELAY 3 (S)
Start-up suppression for the switching condition of preselection 3. See chapter PRESELECTION 1 MENU.

4.10. Preselection 4 Menu

MODE 4		
Switching conditions for preselection 4. see chapter PRESELECTION 1 MENU (except the trailing value)		
		See chapter PRESELECTION 1 MENU
6	RES>=PRES-TRAIL	Trailing PRESELECTION 4: Display value is greater or equal PRESELECTION 4 – PRESELECTION 1 → ON, PRESELECTION 1 is the trailing value from PRESELECTION 4

HYSTERESIS 4

This parameter defines the switching hysteresis of the switch-off point for preselection 4.
See chapter PRESELECTION 1 MENU.

PULSE TIME 4 (S)

Duration of output pulse for the switching condition of preselection 4.
See chapter PRESELECTION 1 MENU.

OUTPUT TARGET 4

Assignment of an output for the switching condition of preselection 4.
See chapter PRESELECTION 1 MENU.

0	NO	No assignment
1	CTRL OUT 1	Switching condition assigned to "Ctrl. Out 1"
2	CTRL OUT 2	Switching condition assigned to "Ctrl. Out 2"
3	CTRL OUT 3	Switching condition assigned to "Ctrl. Out 3"
4	CTRL OUT 4	Switching condition assigned to "Ctrl. Out 4"
5	CTRL OUT 5	Switching condition assigned to "Ctrl. Out 5"
6	CTRL OUT 6	Switching condition assigned to "Ctrl. Out 6"

OUTPUT POLARITY 4

Polarity for the switching condition of preselection 4.
See chapter PRESELECTION 1 MENU.

OUTPUT LOCK 4

Latch for the switching condition of preselection 4.
See chapter PRESELECTION 1 MENU.

START UP DELAY 4 (S)

Start-up suppression for the switching condition of preselection 4.
See chapter PRESELECTION 1 MENU.

4.11. Preselection 5 Menu

MODE 5		
Switching conditions for preselection 5. see chapter PRESELECTION 1 MENU (except the trailing value)		
		See chapter PRESELECTION 1 MENU
6	RES>=PRES-TRAIL	Trailing PRESELECTION 5: Display value is greater or equal PRESELECTION 5 – PRESELECTION 2 → ON, PRESELECTION 2 is the trailing value from PRESELECTION 5

HYSTERESIS 5
This parameter defines the switching hysteresis of the switch-off point for preselection 5. See chapter PRESELECTION 1 MENU.

PULSE TIME 5 (S)
Duration of output pulse for the switching condition of preselection 5. See chapter PRESELECTION 1 MENU.

OUTPUT TARGET 5		
Assignment of an output for the switching condition of preselection 5. See chapter PRESELECTION 1 MENU.		
0	NO	No assignment
1	CTRL OUT 1	Switching condition assigned to "Ctrl. Out 1"
2	CTRL OUT 2	Switching condition assigned to "Ctrl. Out 2"
3	CTRL OUT 3	Switching condition assigned to "Ctrl. Out 3"
4	CTRL OUT 4	Switching condition assigned to "Ctrl. Out 4"
5	CTRL OUT 5	Switching condition assigned to "Ctrl. Out 5"
6	CTRL OUT 6	Switching condition assigned to "Ctrl. Out 6"

OUTPUT POLARITY 5
Polarity for the switching condition of preselection 5. See chapter PRESELECTION 1 MENU.

OUTPUT LOCK 5
Latch for the switching condition of preselection 5. See chapter PRESELECTION 1 MENU.

START UP DELAY 5 (S)
Start-up suppression for the switching condition of preselection 5. See chapter PRESELECTION 1 MENU.

4.12. Preselection 6 Menu

MODE 6		
Switching conditions for preselection 6. see chapter PRESELECTION 1 MENU (except the trailing value)		
		See chapter PRESELECTION 1 MENU
6	RES>=PRES-TRAIL	Trailing PRESELECTION 6: Display value is greater or equal PRESELECTION 6 – PRESELECTION 3 → ON, PRESELECTION 3 is the trailing value from PRESELECTION 6

HYSTERESIS 6
This parameter defines the switching hysteresis of the switch-off point for preselection 6. See chapter PRESELECTION 1 MENU.

PULSE TIME 6 (S)
Duration of output pulse for the switching condition of preselection 6. See chapter PRESELECTION 1 MENU.

OUTPUT TARGET 6		
Assignment of an output for the switching condition of preselection 6. See chapter PRESELECTION 1 MENU.		
0	NO	No assignment
1	CTRL OUT 1	Switching condition assigned to "Ctrl. Out 1"
2	CTRL OUT 2	Switching condition assigned to "Ctrl. Out 2"
3	CTRL OUT 3	Switching condition assigned to "Ctrl. Out 3"
4	CTRL OUT 4	Switching condition assigned to "Ctrl. Out 4"
5	CTRL OUT 5	Switching condition assigned to "Ctrl. Out 5"
6	CTRL OUT 6	Switching condition assigned to "Ctrl. Out 6"

OUTPUT POLARITY 6
Polarity for the switching condition of preselection 6. See chapter PRESELECTION 1 MENU.

OUTPUT LOCK 6
Latch for the switching condition of preselection 6. See chapter PRESELECTION 1 MENU.

START UP DELAY 6 (S)
Start-up suppression for the switching condition of preselection 6. See chapter PRESELECTION 1 MENU.

4.13. Serial Menu

This menu defines the basic settings of serial interface.

UNIT NUMBER		
This parameter defines serial device addresses. The addresses between 11 and 99 can be assigned to the devices. Addresses with zero are not allowed, there are used as broadcast addresses.		
	11	Smallest address
	...	
	99	Highest address

SERIAL BAUD RATE			
This parameter defines the serial baud rate.			
	0	9600	9600 baud
	1	19200	19200 baud
	2	38400	38400 baud

SERIAL FORMAT					
This parameter defines the bit data format.					
	0	7-EVEN-1	7 data	Parity even	1 Stop
	1	7-EVEN-2	7 data	Parity even	2 Stops
	2	7-ODD-1	7 data	Parity odd	1 Stop
	3	7-ODD-2	7 data	Parity odd	2 Stops
	4	7-NONE-1	7 data	no Parity	1 Stop
	5	7-NONE-2	7 data	no Parity	2 Stops
	6	8-EVEN-1	8 data	Parity even	1 Stop
	7	8-ODD-1	8 data	Parity odd	1 Stop
	8	8-NONE-1	8 data	no Parity	1 Stop
	9	8-NONE-2	8 data	no Parity	2 Stops

SERIAL INIT			
This parameter defines the baud rate for the initialization to the user interface OS6.0. With settings larger than 9600 the initialization time can be reduced.			
	0	NO	Initialization with 9600 baud. Then the device operates with the value selected by the user.
	1	YES	Initialization with the baud rate set by SERIAL BAUD RATE. Then the device operates with the value selected by the user.

Fortsetzung „Serial Menu“:

SERIAL PROTOCOL												
Determines the sequence of characters send, when using the serial output for cyclic data transmission under time control (xxxxxxx = value SERIAL VALUE). Setting „1“ removes the unit address from the string which allows a slight faster transmission cycle.												
	0	Transmission report = Unit Nr., +/-, data, LF, CR										
		1	1	+/-	X	X	X	X	X	X	X	LF
	1	Transmission report = +/-, data, LF, CR										
		+/-	X	X	X	X	X	X	X	X	LF	CR

SERIAL TIMER (S)		
This register determines the cycle time in seconds for cycling transmission of SERIAL VALUE when using the serial output. (On a serial request, the cycling transmission is stopped for 20 s)		
	0,000	All cyclic transmission is switched off. The unit will send data upon a serial request or with command SERIAL PRINT.
	...	
	60,000	Cycle time in seconds.

SERIAL VALUE			
This parameter defines the value to be transmitted.			
Einstellung	Code	Bedeutung	
0	:0	Measurement_Result (Result after linking, scaling, filter, etc.)	
1	:1	Analog_Out_Voltage (Analog output modulation (in mV))	
2	:2	Frequency (measured frequency - channel A)	
3	:3	Frequency_2 (measured frequency - channel B)	
4	:4	Counter (total count after linking without scaling, filters, etc.)	
5	:5	Counter_A (counter reading - channel A)	
6	:6	Counter_B (counter reading - channel B)	
7	:7	SSI_Data (read + possibly converted binary SSI value)	
8	:8	SSI_Calc_Result (SSI value incl. SSI zero and SSI offset without scaling, filters, etc.)	
9	:9	Minimum_Value (Minimum value of Measurement_Result)	
10	:0	Maximum_Value (Maximum value of Measurement_Result)	
11	:1	Analog_Out_Current (Analog output modulation (in yA))	
12	:2	Analog_Out_Percentage (Percentage analog output level) (Measurement result in xxx.x %)	

MODBUS		
This parameter enables the Modbus protocol and determines the Modbus address. For details of the Modbus communication please refer to the additional manual Modbus_RTU		
	0	Modbus disabled Serial interface is using Lecom protocol (Motrona default protocol)
	1 ... 247	Modbus enabled: Serial interface is using Modbus RTU protocol The set value is the Modbus address of the device.

4.14. Analog Menu

This menu defines the basic settings of the analog output.

ANALOG FORMAT

This parameter defines the output characteristics. The analogue output is proportional to the display value. With setting ANALOG FORMAT (-10 ... +10 V) in MODE COUNTER the polarity of the analog output depends on the polarity of the display value.

0	-10...10V	-10 ... +10 V
1	0...20mA	0 ... 20 mA
2	4...20mA	4 ... 20 mA

ANALOG START

This parameter defines the start value of the analog conversion. This start value is corresponding to the display value for an analog output of 0 V or 0/4 mA.

-99999999	Smallest end value
0	Default Wert
+99999999	Highest end value

ANALOG END

This parameter defines the end value of the analog conversion. This end value is corresponding to the display value for an analog output of (+/-) 10 V or 20mA.

-99999999	Smallest end value
10000	Default Wert
+99999999	Highest end value

ANALOG GAIN (%)

This parameter specifies the maximum conversion of the analog output in %.

e. g. 102.00 corresponds to a conversion of 10.2 V or 20.4 mA, when the ANALOG END value is reached.

e. g. 95.00 corresponds to a conversion of 9.5 V or 18 mA, when the ANALOG END value is reached.

0,00	Smallest gain
100,00	Default value
110,00	Highest gain

ANALOG OFFSET (%)

This parameter defines the zero offset of the analog output.

z. B. 0.20 result in an offset of 0.02 V or 0.04 mA at ANALOG START value

-99,99	Smallest offset
0	Default value
+99,00	Highest offset

4.15. Command Menu

INPUT 1 ACTION _(function Input 1)			
This parameter defines the function of the input "Ctrl. In 1".			
(s) = static switching (level evaluation), INPUT CONFIG must be set to active LOW / HIGH			
(d) = dynamic switching (edge evaluation) ,INPUT CONFIG must be set to RISING/FALLING EDGE			
0	NO	No function	
1	RESET/SET VALUE	Transfer of the currently detected position value (after bit suppression and possibly performed encoder zero offset shift) into the parameter "SSI offset" - only in "SSI" mode	(d) (s)
2	FREEZE	Freezing of the current measurement result	(s)
3	TEACH ANALOG START	Transfer of the current measurement result in the parameter "Analog Start"	(d)
4	TEACH ANALOG END	Transfer of the current measurement result in the parameter "Analog End"	(d)
5	TEACH PRESELECTION 1	Transfer of the current measurement result into the parameter "Preselection 1"	(d)
6	TEACH PRESELECTION 2	Transfer of the current measurement result into the parameter "Preselection 2"	(d)
7	TEACH PRESELECTION 3	Transfer of the current measurement result into the parameter "Preselection 3"	(d)
8	TEACH PRESELECTION 4	Transfer of the current measurement result into the parameter "Preselection 4"	(d)
9	TEACH PRESELECTION 5	Transfer of the current measurement result into the parameter "Preselection 5"	(d)
10	TEACH PRESELECTION 6	Transfer of the current measurement result into the parameter "Preselection 6"	(d)
11	RESET MIN/MAX	Reset the minimum / maximum value	(d) (s)
12	LOCK RELEASE	Release latching of all outputs	(d)
13	SERIAL PRINT	Sending of serial data, see parameter SERIAL VALUE	(d)
14	ACTIVATE DATA	N.A.	
15	STORE DATA	N.A.	
16	TESTPROGRAM	N.A.	
17	CLEAR LOOP TIME	Reset of the maximum "Loop Time"	(d)
18	RESET/SET COUNTER A	Reset / set the counter value of channel A to the set value in SET VALUE A - only in "COUNTER" mode	(d) (s)
19	RESET/SET COUNTER B	Reset / set the counter value of channel B to the set value in SET VALUE B - only in "COUNTER" mode	(d) (s)
20	RESET/SET COUNTER	Reset / set the counter values of channel A and B to the set value in SET VALUE A and B - only in "COUNTER" mode	(d) (s)
21	ZERO POSITION	Transfer of the current SSI position in the parameter "SSI-Zero" (encoder zero offset) - only in mode "SSI"	(d) (s)
22	FACTORY SETTINGS	Device is reset to factory settings.	(d)

Continuation „Command Menu“:

INPUT 1 CONFIG

This parameter defines the switching characteristics of the input "Ctrl. In 1".

0	ACTIVE LOW	Active at „LOW“ (static)
1	ACTIVE HIGH	Active at „HIGH“ (static)
2	RISING EDGE	Activate at rising edge
3	FALLING EDGE	Activate at falling edge

INPUT 2 ACTION

This parameter defines the function of the input "Ctrl. In 2".
See parameter INPUT 1 ACTION.

INPUT 2 CONFIG

This parameter defines the switching characteristics of the input "Ctrl. In 2".
See parameter INPUT 1 CONFIG.

INPUT 3 ACTION

This parameter defines the function of the input "Ctrl. In 3".
See parameter INPUT 1 ACTION.

INPUT 3 CONFIG

This parameter defines the switching characteristics of the input "Ctrl. In 3".
See parameter INPUT 1 CONFIG.

INPUT 4 ACTION

This parameter defines the function of the input "Ctrl. In 4".
See parameter INPUT 1 ACTION.

INPUT 4 CONFIG

This parameter defines the switching characteristics of the input "Ctrl. In 4".
See parameter INPUT 1 CONFIG.

INPUT 5 ACTION

This parameter defines the function of the input "Ctrl. In 5".
See parameter INPUT 1 ACTION.

INPUT 5 CONFIG

This parameter defines the switching characteristics of the input "Ctrl. In 5".
See parameter INPUT 1 CONFIG.

INPUT 6 ACTION (FACTORY SETTINGS)

This parameter is fixed to "Factory Settings" and can not be changed.

INPUT 6 CONFIG (RISING EDGE)

This parameter is fixed to "Rising Edge" and can not be changed.

4.16. Linearization Menu

The linearization function is defined in this menu.

Linearization description and examples are shown in the appendix.

P1(X) ... P24(X)		
X-coordinate of the linearization point. This is the value that the device would generate without linearization depending on the input signal.		
	-99999999	Smallest X-coordinate
	0	Default value
	+99999999	Largest X-coordinate

P1(Y) ... P24(Y)		
Y-coordinate of the linearization point. This is the value that the device should generate instead of the x coordinate. e.g. P2 (X) is replaced by P2 (Y).		
	-99999999	Smallest X-coordinate
	0	Default value
	+99999999	Largest X-coordinate

5. Appendix

6.1. Data readout via serial interface

All codes shown in the parameter SERIAL VALUE are available for serial readout by PC or PLC. The communication of Motrona devices is based on the Drivecom protocol according to ISO 1745 or the Modbus RTU protocol. All protocol details can be found in our manual SERPRO (Drivecom) which is available for download from our homepage www.motrona.com and in the chapter "Modbus RTU Interface" in this manual.

To request for a data transmission you must send the following request string to the converter:

EOT	AD1	AD2	C1	C2	ENQ
-----	-----	-----	----	----	-----

EOT = control character (Hex 04)

AD1 = unit address, High Byte

AD2 = unit address, Low Byte

C1 = register code, High Byte

C2 = register code, Low Byte

ENQ = control character (Hex 05)

The following example shows the request string for readout of the actual input frequency of a monitor (Code=1) from a unit with unit address 11:

ASCII-Code:	ASCII-Code:	EOT	1	1	:	1	ENQ
Hex-Code:	Hexadecimal:	04	31	31	3A	31	05
Binary-Code:	Binary:	0000 0100	0011 0001	0011 0001	0011 1010	0011 0001	0000 0101

After a correct request, the unit will respond:

STX	C1	C2	xxxxx	ETX	BCC
-----	----	----	-------	-----	-----

STX = control character (Hex 02)

C1 = register code, High Byte

C2 = register code, Low Byte

xxxxx = readout data

ETX = control character (Hex 03)

BCC = block check character

6.2 Modbus RTU Interface

The Modbus interface of the touchMatrix series is a standard Modbus RTU Slave and provides the following Modbus functions:

- Read Coils
- Write Single Coil
- Read Holding Registers
- Write Multiple Registers
- Diagnosis

For the operation of the interface module and the understanding of this manual basic knowledge in Modbus RTU communication is presupposed.

6.2.1 Parameter setting

Required parameter settings in DX350 / DX355 "Serial menu":

UNIT NUMMER

Not valid for Modbus communication

(For setting of Modbus address see parameter "MODBUS")

SERIAL BAUD RATE

This parameter defines the serial baud rate

0	9600	9600 baud
1	19200	19200 baud
2	38400	38400 baud

SERIAL FORMAT

This parameter defines the bit data format.

0	7-EVEN-1	Do not use with Modbus protocol		
1	7-EVEN-2			
2	7-ODD-1			
3	7-ODD-2			
4	7-NONE-1			
5	7-NONE-2			
6	8-EVEN-1	8 data bits	Parity even	1 stop bit
7	8-ODD-1	8 data bits	Parity odd	1 stop bit
8	8-NONE-1	Do not use with Modbus protocol		
9	8-NONE-2	8 data bits	no Parity	2 stop bits

Continuation "Parameter setting":

SERIAL INIT Not valid for Modbus communication	
SERIAL PROTOCOL Not valid for Modbus communication	
SERIAL TIMER (S) Not valid for Modbus communication	
SERIAL VALUE Not valid for Modbus communication	
MODBUS This parameter enables the Modbus protocol and determines the Modbus address.	
0	Do not use for Modbus protocol (Modbus disabled)
1 ... 247	Modbus enabled: Serial interface is using Modbus RTU protocol The number set here determines the Modbus node address.

6.2.2 Modbus Communication

The following Modbus functions are available:

6.2.2.1 Read Holding Registers and Write Multiple Registers

With the functions "Read Holding Registers" and "Write Multiple Registers" it is possible to access all registers of the device.

All variables (actual data) and status registers are mapped to Modbus Holding Registers. However, as all registers of the device are 32 bit registers but Modbus Holding registers are only 16 bit registers, each register of the device requires two Holding registers. (For this reason the use of Modbus function "Write Single Register" is not possible.)

It is only possible to access to one single register of the touchMATRIX device by each read or write operation, therefore the "Quantity (or number) of registers" in the Modbus request must always be 2.

Access to parameters

Holding Register 0x0000 / 0x0001 hex and following allow access to the device parameters.

The holding register numbers for a certain parameter can be calculated by the parameter # that can be found in the parameter table in the touchMatrix device manual:

Holding Register low = (parameter #) x 2

Holding Register high = (parameter #) x 2 + 1

Example:

Access to parameter # 51 "PRESELECTION 1" by Holding Register 0x0066 and 0x0067 hex.

Access to actual data

Holding Register 0x1000 / 0x1001 hex and following allow access to variables of the device (actual data registers):

Holding Register 0x1000 / 0x1001 hex → Actual data with serial Code ":0" (Display value)

Holding Register 0x1002 / 0x1003 hex → Actual data with serial Code ":1"

Holding Register 0x1004 / 0x1005 hex → Actual data with serial Code ":2"

Holding Register 0x1006 / 0x1007 hex → Actual data with serial Code ":3"

etc.

Access to status registers

Holding Register 0x2000 / 0x2001 hex and following allow access to status registers of the device:

Holding Register 0x2000 / 0x2001 hex → Output Status (Ctrl. Out status, read only)

Holding Register 0x2002 / 0x2003 hex → Serial Commands

Holding Register 0x2004 / 0x2005 hex → External Command (Ctrl. In status, read only)

Holding Register 0x2006 / 0x2007 hex → All Commands (read only)

6.2.2.2 Read Coils and Write Single Coil

With the functions "Read Coils" and "Write Single Coil" it is possible to read and set/reset single commands:

Coil number	Serial code of command	Command	
0	54	RESET/SET	Transfer of the currently detected position value (after bit suppression and possibly performed encoder zero offset shift) into the parameter "SSI offset" - only in "SSI" mode
1	55	FREEZE DISPLAY	Freezing of the current measurement result
2	56	TEACH ANALOG START	Transfer of the current measurement result in the parameter "Analog Start"
3	57	TEACH ANALOG END	Transfer of the current measurement result in the parameter "Analog End"
4	58	TEACH PRESELECTION 1	Transfer of the current measurement result into the parameter "Preselection 1"
5	59	TEACH PRESELECTION 2	Transfer of the current measurement result into the parameter "Preselection 2"
6	60	TEACH PRESELECTION 3	Transfer of the current measurement result into the parameter "Preselection 3"
7	61	TEACH PRESELECTION 4	Transfer of the current measurement result into the parameter "Preselection 4"
8	62	TEACH PRESELECTION 5	Transfer of the current measurement result into the parameter "Preselection 5"
9	63	TEACH PRESELECTION 6	Transfer of the current measurement result into the parameter "Preselection 6"
10	64	RESET MIN/MAX	Reset the minimum / maximum value
11	65	LOCK RELEASE	Release latching of all outputs
12	66	SERIAL PRINT (do not use with Modbus)	Sending of serial data, see parameter SERIAL VALUE

13	67	ACTIVATE DATA (not required with Modbus)	The data is activated.
14	68	STORE DATA	Store to EEPROM
15	69	TESTPROGRAM (do not use with Modbus)	Testprogram (do not use with Modbus)

6.2.3 Diagnose

The device supports the diagnostics subfunction 00 "Return Query Data". Other diagnostics functions are not available.

6.2. Parameter / serial codes

#	Menu	Name	Code	Min	Max	Default
0	GENERAL MENU	MODE	00	0	3	0
1	GENERAL MENU	ENCODER PROPERTIES	01	0	4	0
2	GENERAL MENU	ENCODER DIRECTION	02	0	1	0
3	GENERAL MENU	AVERAGE FILTER	03	0	4	0
4	GENERAL MENU	FACTOR	04	-99999999	99999999	1
5	GENERAL MENU	DIVIDER	05	-99999999	99999999	1
6	GENERAL MENU	ADDITIVE VALUE	06	-99999999	99999999	0
7	GENERAL MENU	LINEARIZATION MODE	07	0	2	0
8	GENERAL MENU	BACKUP MEMORY	08	0	1	1
9	GENERAL MENU	FACTORY SETTINGS	09	0	1	0
10	GENERAL MENU	---	10	0	0	0
11	GENERAL MENU	---	11	0	0	0
12	GENERAL MENU	---	12	0	0	0
13	MODE FREQUENCY	FREQUENCY MODE	13	0	5	0
14	MODE FREQUENCY	FREQUENCY BASE	14	0	3	2
15	MODE FREQUENCY	SAMPLING TIME 1 (S)	15	1	9999	100
16	MODE FREQUENCY	WAIT TIME 1 (S)	16	1	7999	100
17	MODE FREQUENCY	STANDSTILL TIME 1 (S)	17	1	9999	1
18	MODE FREQUENCY	SAMPLING TIME 2 (S)	18	1	9999	100
19	MODE FREQUENCY	WAIT TIME 2 (S)	19	1	7999	100
20	MODE FREQUENCY	---	20	0	0	0
21	MODE FREQUENCY	---	21	0	0	0
22	MODE FREQUENCY	---	22	0	0	0
23	MODE COUNTER	COUNT MODE	23	0	5	3
24	MODE COUNTER	FACTOR A	24	1	99999999	100000
25	MODE COUNTER	SET VALUE A	25	-99999999	99999999	0
26	MODE COUNTER	FACTOR B	26	1	99999999	100000
27	MODE COUNTER	SET VALUE B	27	-99999999	99999999	0
28	MODE COUNTER	ROUND LOOP VALUE	28	0	99999999	0
29	MODE COUNTER	---	29	0	0	0
30	MODE COUNTER	---	30	0	0	0
31	MODE SSI	SSI MODE	31	0	1	0
32	MODE SSI	ENCODER RESOLUTION	32	10	32	25
33	MODE SSI	DATA FORMAT	33	0	1	0
34	MODE SSI	BAUD RATE	34	0	5	2
35	MODE SSI	SSI ZERO	35	0	999999999	0
36	MODE SSI	HIGH BIT	36	1	32	25
37	MODE SSI	LOW BIT	37	1	32	1
38	MODE SSI	SSI OFFSET	38	0	999999999	0
39	MODE SSI	ROUND LOOP VALUE	39	0	99999999	0
40	MODE SSI	SAMPLING TIME (S)	40	1	9999	10
41	MODE SSI	ERROR BIT	41	0	32	0
42	MODE SSI	ERROR POLARITY	42	0	1	0
43	MODE SSI	---	43	0	0	0
44	MODE SSI	---	44	0	0	0
45	MODE SSI	---	45	0	0	0

Continuation „Parameter / serial codes“:

#	Menu	Name	Code	Min	Max	Default
46	PRESELECTION VALUES	PRESELECTION 1	A0	-99999999	99999999	1000
47	PRESELECTION VALUES	PRESELECTION 2	A1	-99999999	99999999	2000
48	PRESELECTION VALUES	PRESELECTION 3	A2	-99999999	99999999	3000
49	PRESELECTION VALUES	PRESELECTION 4	A3	-99999999	99999999	4000
50	PRESELECTION VALUES	PRESELECTION 5	A4	-99999999	99999999	5000
51	PRESELECTION VALUES	PRESELECTION 6	A5	-99999999	99999999	6000
52	PRESELECTION 1 MENU	MODE 1	A6	0	8	0
53	PRESELECTION 1 MENU	HYSTERESIS 1	A7	0	99999	0
54	PRESELECTION 1 MENU	PULSE TIME 1 (S)	A8	0	60000	0
55	PRESELECTION 1 MENU	OUTPUT TARGET 1	A9	0	6	1
56	PRESELECTION 1 MENU	OUTPUT POLARITY 1	B0	0	1	0
57	PRESELECTION 1 MENU	OUTPUT LOCK 1	B1	0	1	0
58	PRESELECTION 1 MENU	START UP DELAY 1 (S)	B2	0	60000	0
59	PRESELECTION 1 MENU	___	B3	0	0	0
60	PRESELECTION 1 MENU	___	B4	0	0	0
61	PRESELECTION 1 MENU	___	B5	0	0	0
62	PRESELECTION 1 MENU	___	B6	0	0	0
63	PRESELECTION 2 MENU	MODE 2	B7	0	8	0
64	PRESELECTION 2 MENU	HYSTERESIS 2	B8	0	99999	0
65	PRESELECTION 2 MENU	PULSE TIME 2 (S)	B9	0	60000	0
66	PRESELECTION 2 MENU	OUTPUT TARGET 2	C0	0	6	2
67	PRESELECTION 2 MENU	OUTPUT POLARITY 2	C1	0	1	0
68	PRESELECTION 2 MENU	OUTPUT LOCK 2	C2	0	1	0
69	PRESELECTION 2 MENU	START UP DELAY 2 (S)	C3	0	60000	0
70	PRESELECTION 2 MENU	___	C4	0	0	0
71	PRESELECTION 2 MENU	___	C5	0	0	0
72	PRESELECTION 2 MENU	___	C6	0	0	0
73	PRESELECTION 2 MENU	___	C7	0	0	0
74	PRESELECTION 3 MENU	MODE 3	C8	0	8	0
75	PRESELECTION 3 MENU	HYSTERESIS 3	C9	0	99999	0
76	PRESELECTION 3 MENU	PULSE TIME 3 (S)	D0	0	60000	0
77	PRESELECTION 3 MENU	OUTPUT TARGET 3	D1	0	6	3
78	PRESELECTION 3 MENU	OUTPUT POLARITY 3	D2	0	1	0
79	PRESELECTION 3 MENU	OUTPUT LOCK 3	D3	0	1	0
80	PRESELECTION 3 MENU	START UP DELAY 3 (S)	D4	0	60000	0
81	PRESELECTION 3 MENU	___	D5	0	0	0
82	PRESELECTION 3 MENU	___	D6	0	0	0
83	PRESELECTION 3 MENU	___	D7	0	0	0
84	PRESELECTION 3 MENU	___	D8	0	0	0
85	PRESELECTION 4 MENU	MODE 4	D9	0	8	0
86	PRESELECTION 4 MENU	HYSTERESIS 4	E0	0	99999	0
87	PRESELECTION 4 MENU	PULSE TIME 4 (S)	E1	0	60000	0
88	PRESELECTION 4 MENU	OUTPUT TARGET 4	E2	0	6	4
89	PRESELECTION 4 MENU	OUTPUT POLARITY 4	E3	0	1	0
90	PRESELECTION 4 MENU	OUTPUT LOCK 4	E4	0	1	0
91	PRESELECTION 4 MENU	START UP DELAY 4 (S)	E5	0	60000	0

Continuation „Parameter / serial codes“:

#	Menu	Name	Code	Min	Max	Default
92	PRESELECTION 4 MENU	___	E6	0	0	0
93	PRESELECTION 4 MENU	___	E7	0	0	0
94	PRESELECTION 4 MENU	___	E8	0	0	0
95	PRESELECTION 4 MENU	___	E9	0	0	0
96	PRESELECTION 5 MENU	MODE 5	F0	0	8	0
97	PRESELECTION 5 MENU	HYSTERESIS 5	F1	0	99999	0
98	PRESELECTION 5 MENU	PULSE TIME 5 (S)	F2	0	60000	0
99	PRESELECTION 5 MENU	OUTPUT TARGET 5	F3	0	6	5
100	PRESELECTION 5 MENU	OUTPUT POLARITY 5	F4	0	1	0
101	PRESELECTION 5 MENU	OUTPUT LOCK 5	F5	0	1	0
102	PRESELECTION 5 MENU	START UP DELAY 5 (S)	F6	0	60000	0
103	PRESELECTION 5 MENU	___	F7	0	0	0
104	PRESELECTION 5 MENU	___	F8	0	0	0
105	PRESELECTION 5 MENU	___	F9	0	0	0
106	PRESELECTION 5 MENU	___	G0	0	0	0
107	PRESELECTION 6 MENU	MODE 6	G1	0	8	0
108	PRESELECTION 6 MENU	HYSTERESIS 6	G2	0	99999	0
109	PRESELECTION 6 MENU	PULSE TIME 6 (S)	G3	0	60000	0
110	PRESELECTION 6 MENU	OUTPUT TARGET 6	G4	0	6	6
111	PRESELECTION 6 MENU	OUTPUT POLARITY 6	G5	0	1	0
112	PRESELECTION 6 MENU	OUTPUT LOCK 6	G6	0	1	0
113	PRESELECTION 6 MENU	START UP DELAY 6 (S)	G7	0	60000	0
114	PRESELECTION 6 MENU	___	G8	0	0	0
115	PRESELECTION 6 MENU	___	G9	0	0	0
116	PRESELECTION 6 MENU	___	H0	0	0	0
117	PRESELECTION 6 MENU	___	H1	0	0	0
118	SERIAL MENU	UNIT NUMBER	90	11	99	11
119	SERIAL MENU	SERIAL BAUD RATE	91	0	2	0
120	SERIAL MENU	SERIAL FORMAT	92	0	9	0
121	SERIAL MENU	SERIAL INIT	9~	0	1	0
122	SERIAL MENU	SERIAL PROTOCOL	H2	0	1	0
123	SERIAL MENU	SERIAL TIMER (S)	H3	0	60000	0
124	SERIAL MENU	SERIAL VALUE	H4	0	3	0
125	SERIAL MENU	MODBUS	H5	0	247	0
126	SERIAL MENU	___	H6	0	0	0
127	SERIAL MENU	___	H7	0	0	0
128	ANALOG MENU	ANALOG FORMAT	H8	0	2	0
129	ANALOG MENU	ANALOG START	H9	-99999999	99999999	0
130	ANALOG MENU	ANALOG END	I0	-99999999	99999999	10000
131	ANALOG MENU	ANALOG GAIN %	I1	0	11000	10000
132	ANALOG MENU	ANALOG OFFSET %	I2	-9999	9999	0
133	COMMAND MENU	INPUT 1 ACTION	I3	0	22	0
134	COMMAND MENU	INPUT 1 CONFIG.	I4	0	3	2
135	COMMAND MENU	INPUT 2 ACTION	I5	0	22	0
136	COMMAND MENU	INPUT 2 CONFIG.	I6	0	3	2
137	COMMAND MENU	INPUT 3 ACTION	I7	0	22	0

Continuation „Parameter / serial codes“:

#	Menu	Name	Code	Min	Max	Default
138	COMMAND MENU	INPUT 3 CONFIG.	I8	0	3	2
139	COMMAND MENU	INPUT 4 ACTION	I9	0	22	0
140	COMMAND MENU	INPUT 4 CONFIG.	J0	0	3	2
141	COMMAND MENU	INPUT 5 ACTION	J1	0	22	0
142	COMMAND MENU	INPUT 5 CONFIG.	J2	0	3	2
143	COMMAND MENU	INPUT 6 ACTION	J3	22	22	22
144	COMMAND MENU	INPUT 6 CONFIG.	J4	2	2	2
145	COMMAND MENU	—	J5	0	0	0
146	COMMAND MENU	—	J6	0	0	0
147	COMMAND MENU	—	J7	0	0	0
148	COMMAND MENU	—	J8	0	0	0
149	COMMAND MENU	—	J9	0	0	0
150	COMMAND MENU	—	K0	0	0	0
151	LINEARIZATION MENU	P1(X)	K1	-99999999	99999999	0
152	LINEARIZATION MENU	P1(Y)	K2	-99999999	99999999	0
153	LINEARIZATION MENU	P2(X)	K3	-99999999	99999999	0
154	LINEARIZATION MENU	P2(Y)	K4	-99999999	99999999	0
155	LINEARIZATION MENU	P3(X)	K5	-99999999	99999999	0
156	LINEARIZATION MENU	P3(Y)	K6	-99999999	99999999	0
157	LINEARIZATION MENU	P4(X)	K7	-99999999	99999999	0
158	LINEARIZATION MENU	P4(Y)	K8	-99999999	99999999	0
159	LINEARIZATION MENU	P5(X)	K9	-99999999	99999999	0
160	LINEARIZATION MENU	P5(Y)	L0	-99999999	99999999	0
161	LINEARIZATION MENU	P6(X)	L1	-99999999	99999999	0
162	LINEARIZATION MENU	P6(Y)	L2	-99999999	99999999	0
163	LINEARIZATION MENU	P7(X)	L3	-99999999	99999999	0
164	LINEARIZATION MENU	P7(Y)	L4	-99999999	99999999	0
165	LINEARIZATION MENU	P8(X)	L5	-99999999	99999999	0
166	LINEARIZATION MENU	P8(Y)	L6	-99999999	99999999	0
167	LINEARIZATION MENU	P9(X)	L7	-99999999	99999999	0
168	LINEARIZATION MENU	P9(Y)	L8	-99999999	99999999	0
169	LINEARIZATION MENU	P10(X)	L9	-99999999	99999999	0
170	LINEARIZATION MENU	P10(Y)	M0	-99999999	99999999	0
171	LINEARIZATION MENU	P11(X)	M1	-99999999	99999999	0
172	LINEARIZATION MENU	P11(Y)	M2	-99999999	99999999	0
173	LINEARIZATION MENU	P12(X)	M3	-99999999	99999999	0
174	LINEARIZATION MENU	P12(Y)	M4	-99999999	99999999	0
175	LINEARIZATION MENU	P13(X)	M5	-99999999	99999999	0
176	LINEARIZATION MENU	P13(Y)	M6	-99999999	99999999	0
177	LINEARIZATION MENU	P14(X)	M7	-99999999	99999999	0
178	LINEARIZATION MENU	P14(Y)	M8	-99999999	99999999	0
179	LINEARIZATION MENU	P15(X)	M9	-99999999	99999999	0
180	LINEARIZATION MENU	P15(Y)	N0	-99999999	99999999	0
181	LINEARIZATION MENU	P16(X)	N1	-99999999	99999999	0
182	LINEARIZATION MENU	P16(Y)	N2	-99999999	99999999	0
183	LINEARIZATION MENU	P17(X)	N3	-99999999	99999999	0

Continuation „Parameter / serial codes“:

	Menu	Name	Code	Min	Max	Default
184	LINEARIZATION MENU	P17(Y)	N4	-99999999	99999999	0
185	LINEARIZATION MENU	P18(X)	N5	-99999999	99999999	0
186	LINEARIZATION MENU	P18(Y)	N6	-99999999	99999999	0
187	LINEARIZATION MENU	P19(X)	N7	-99999999	99999999	0
188	LINEARIZATION MENU	P19(Y)	N8	-99999999	99999999	0
189	LINEARIZATION MENU	P20(X)	N9	-99999999	99999999	0
190	LINEARIZATION MENU	P20(Y)	00	-99999999	99999999	0
191	LINEARIZATION MENU	P21(X)	01	-99999999	99999999	0
192	LINEARIZATION MENU	P21(Y)	02	-99999999	99999999	0
193	LINEARIZATION MENU	P22(X)	03	-99999999	99999999	0
194	LINEARIZATION MENU	P22(Y)	04	-99999999	99999999	0
195	LINEARIZATION MENU	P23(X)	05	-99999999	99999999	0
196	LINEARIZATION MENU	P23(Y)	06	-99999999	99999999	0
197	LINEARIZATION MENU	P24(X)	07	-99999999	99999999	0
198	LINEARIZATION MENU	P24(Y)	08	-99999999	99999999	0

Serial codes of commands:

Serial Code	Command
54	RESET/SET
55	FREEZE DISPLAY
56	TEACH ANALOG START
57	TEACH ANALOG END
58	TEACH PRESELECTION 1
59	TEACH PRESELECTION 2
60	TEACH PRESELECTION 3
61	TEACH PRESELECTION 4
62	TEACH PRESELECTION 5
63	TEACH PRESELECTION 6
64	RESET MIN/MAX
65	LOCK RELEASE
66	SERIAL PRINT
67	ACTIVATE DATA
68	STORE DATA
69	TESTPROGRAM

6.3. Linearization

The linearization function of this unit allows converting a linear input signal into a non-linear developing (or vice versa). There are 24 programmable x/y coordinates available, which can be set in any desired distance over the full conversion range. Between two coordinates, the unit uses linear interpolation. Therefore it is advisable to use more coordinates in a range with strong curves and only a few coordinates where the curvature is less.

⁵ To specify an individual linearization curve, the parameter LINEARISAZATION MODE must be set to either 1 QUADRANT or 4 QUADRANT (see following diagram).

⁶ The parameters P1(X) to P24(X) are used to specify the coordinates on the x-axis. These are the measuring values that the unit normally would generate according to the actual input signal.

⁷ Now enter the attached values to parameter P1(Y) to P24(Y). These are the values that the unit will generate instead of the x- values, i.e. P5(Y) replaces P5(X) etc.

The X-Coordinates must use continuously increasing settings, i.e. P1(X) must have the lowest and P24(X) must have the highest setting. If the measured value is bigger than the last defined X-value, the corresponding Y-value is displayed.

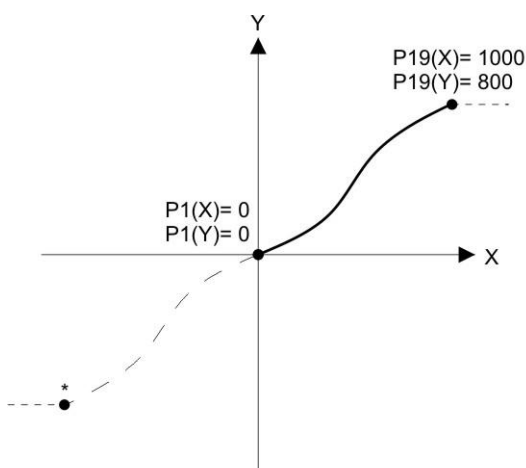

Example: Linearization Mode: 1 Quadrant

* Linearization is point symmetric to 1. Quadrant

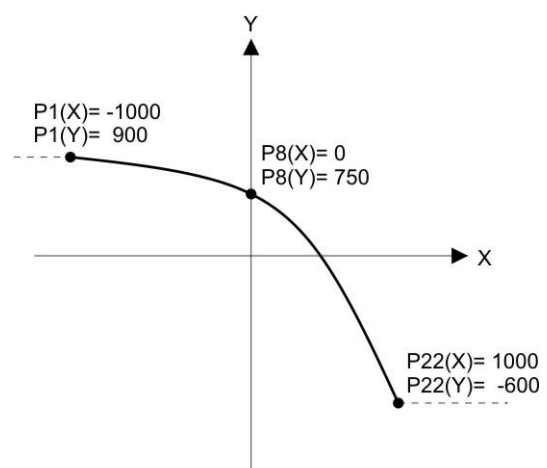

Example: Linearization Mode: 4 Quadrant

Mode: 1 Quadrant:

P1(X) must be set to zero. Linearization is only defined in the positive range and the negative range will be mirrored symmetric to central point.

Mode: 4 Quadrant:

P1(X) can also be set to a negative value. If the measured value is smaller than P1(X), P1(Y) is displayed.

Application Example:

The picture below shows a watergate where the opening is picked up by means of an incremental encoder. We would like to display the clearance of the gate "d", but the existing encoder information is proportional to the angular information φ .

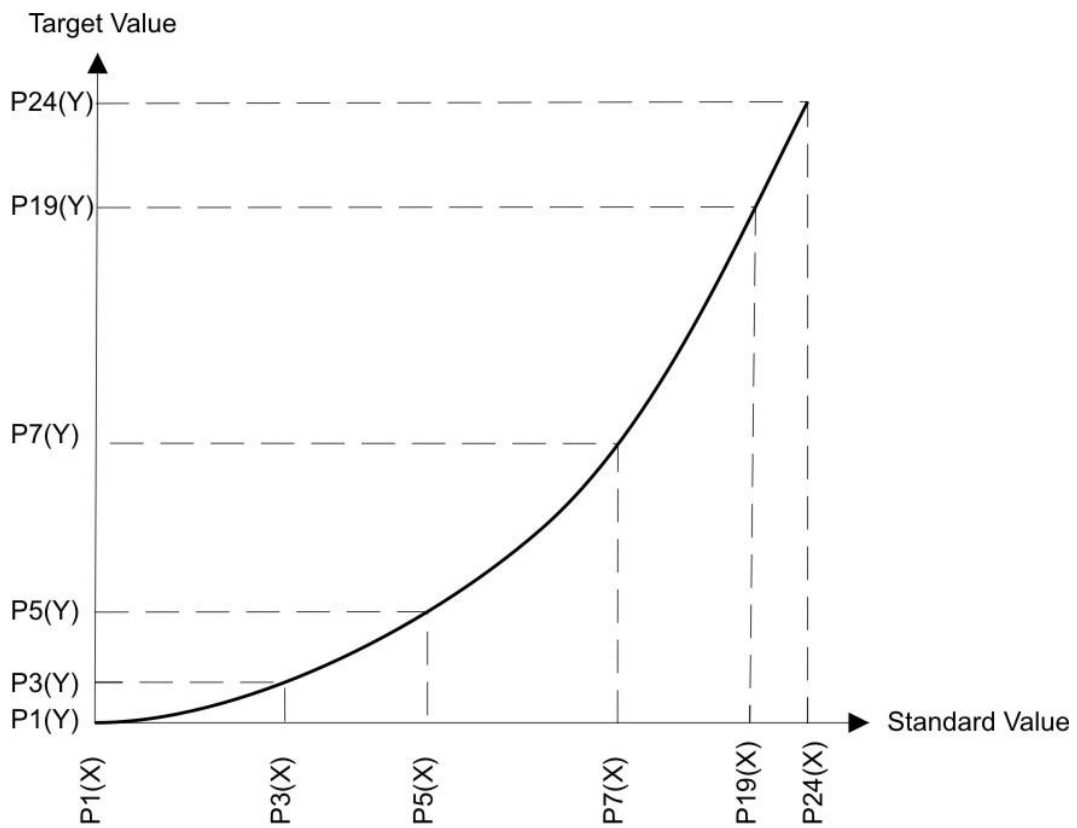
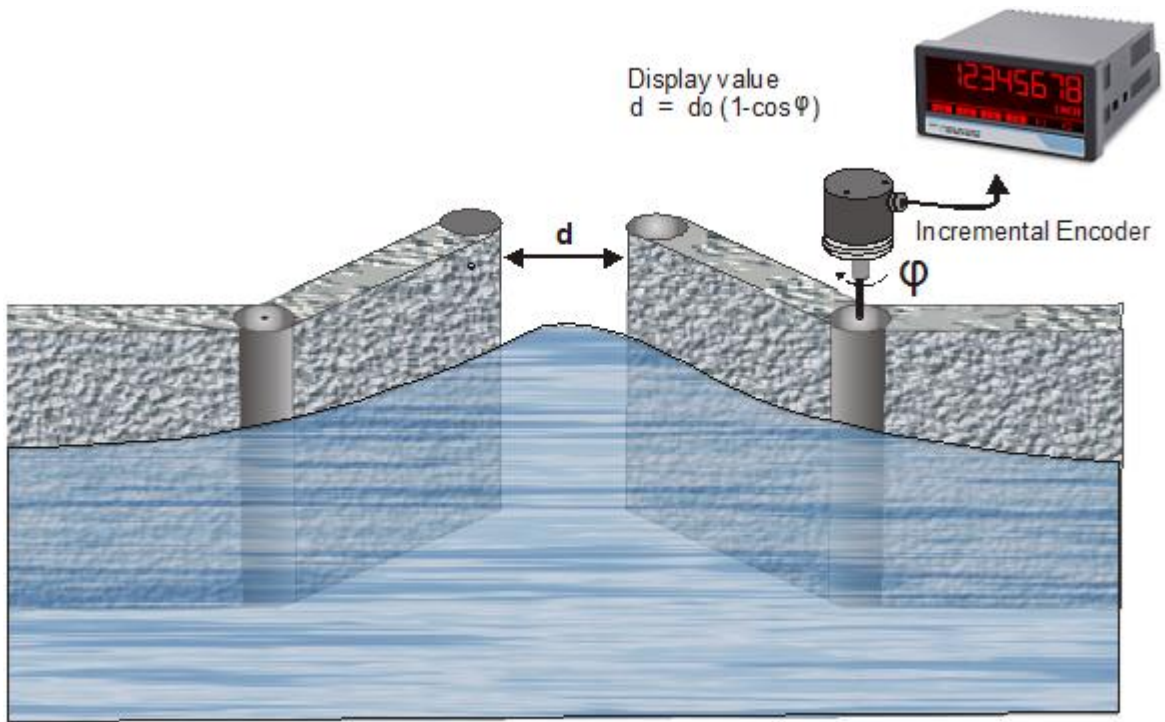

6.4. Reading SSI-Value

The received data is always filled to 32 bit data length.

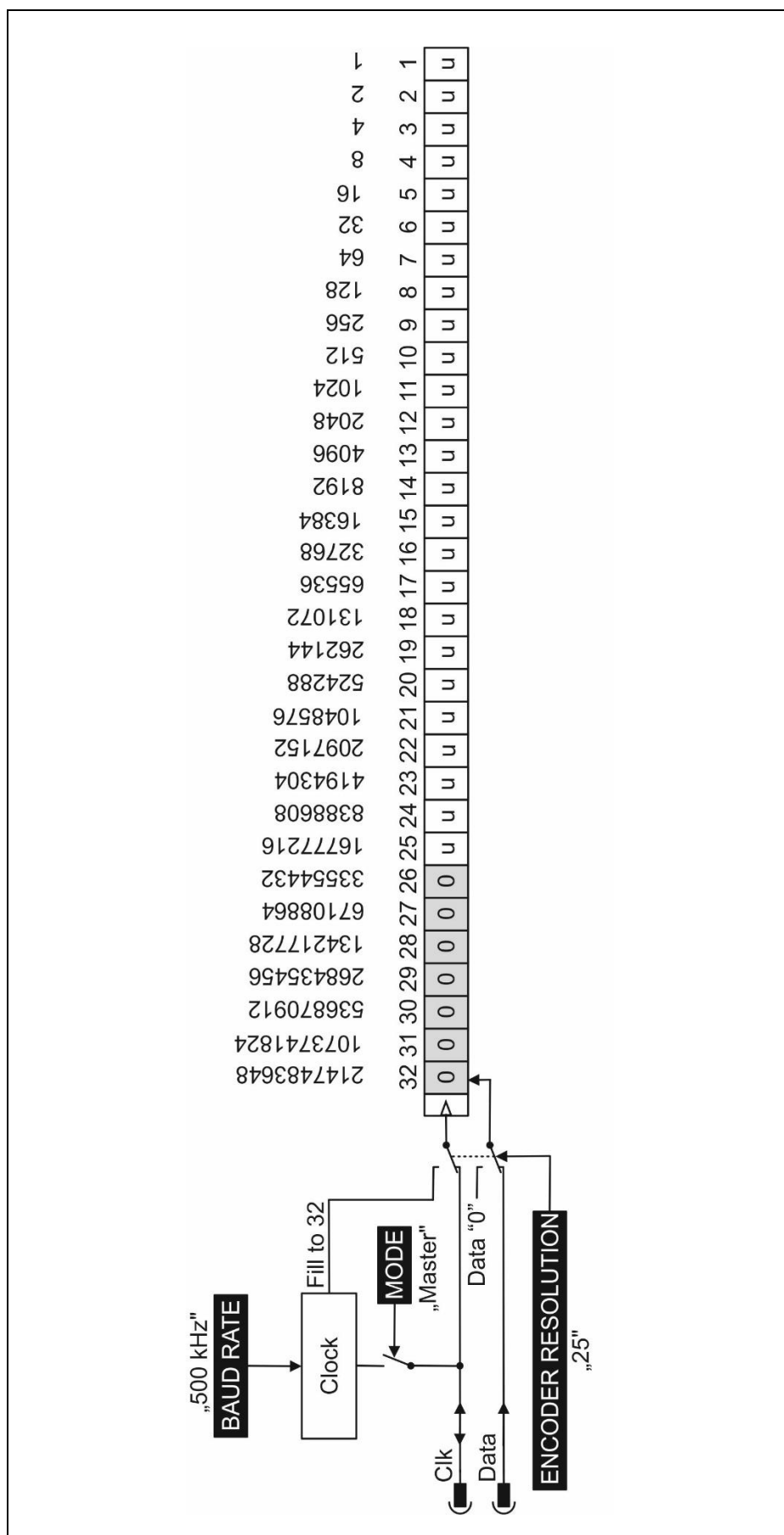

6.5. Internal processing and calculation of SSI data

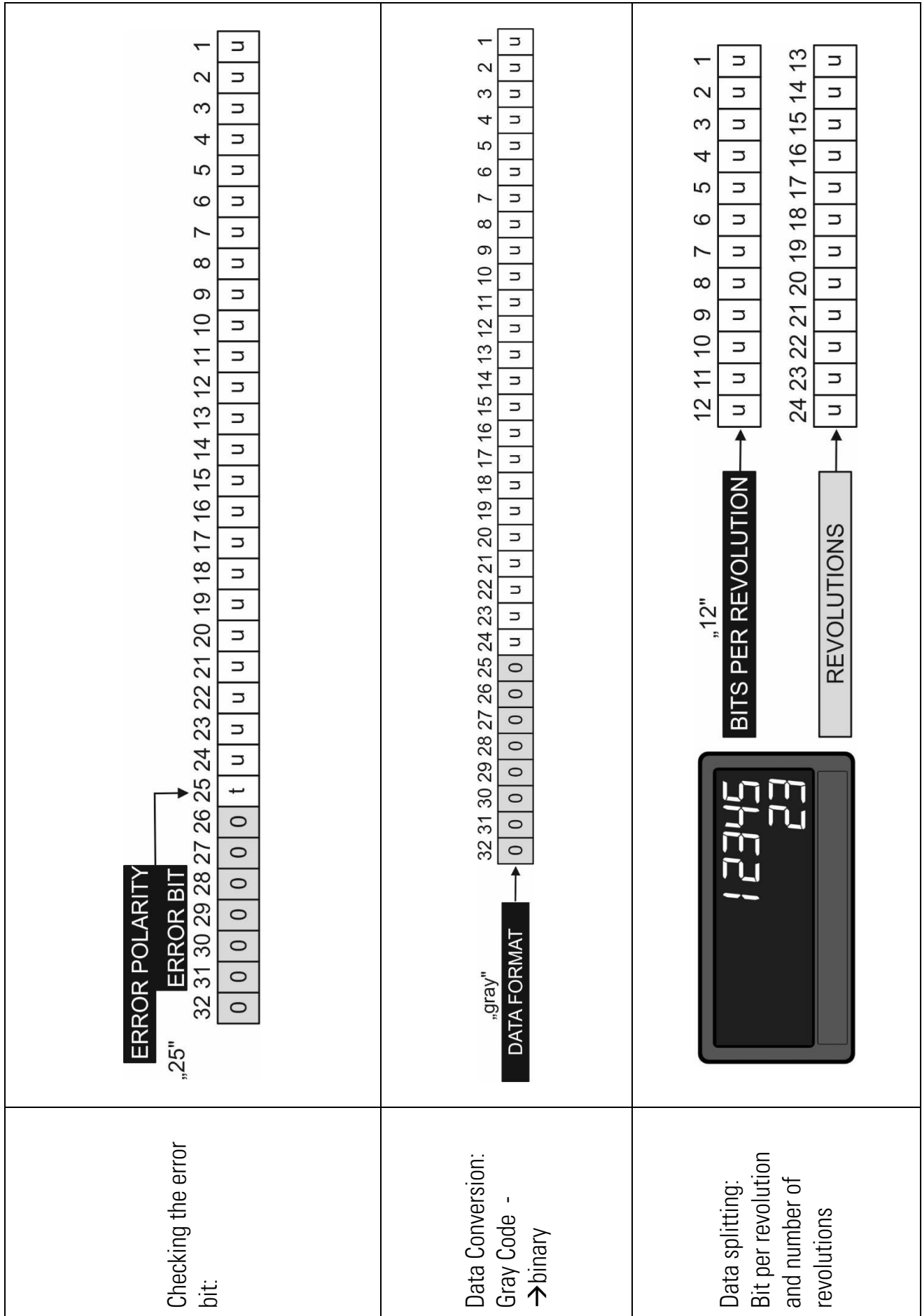

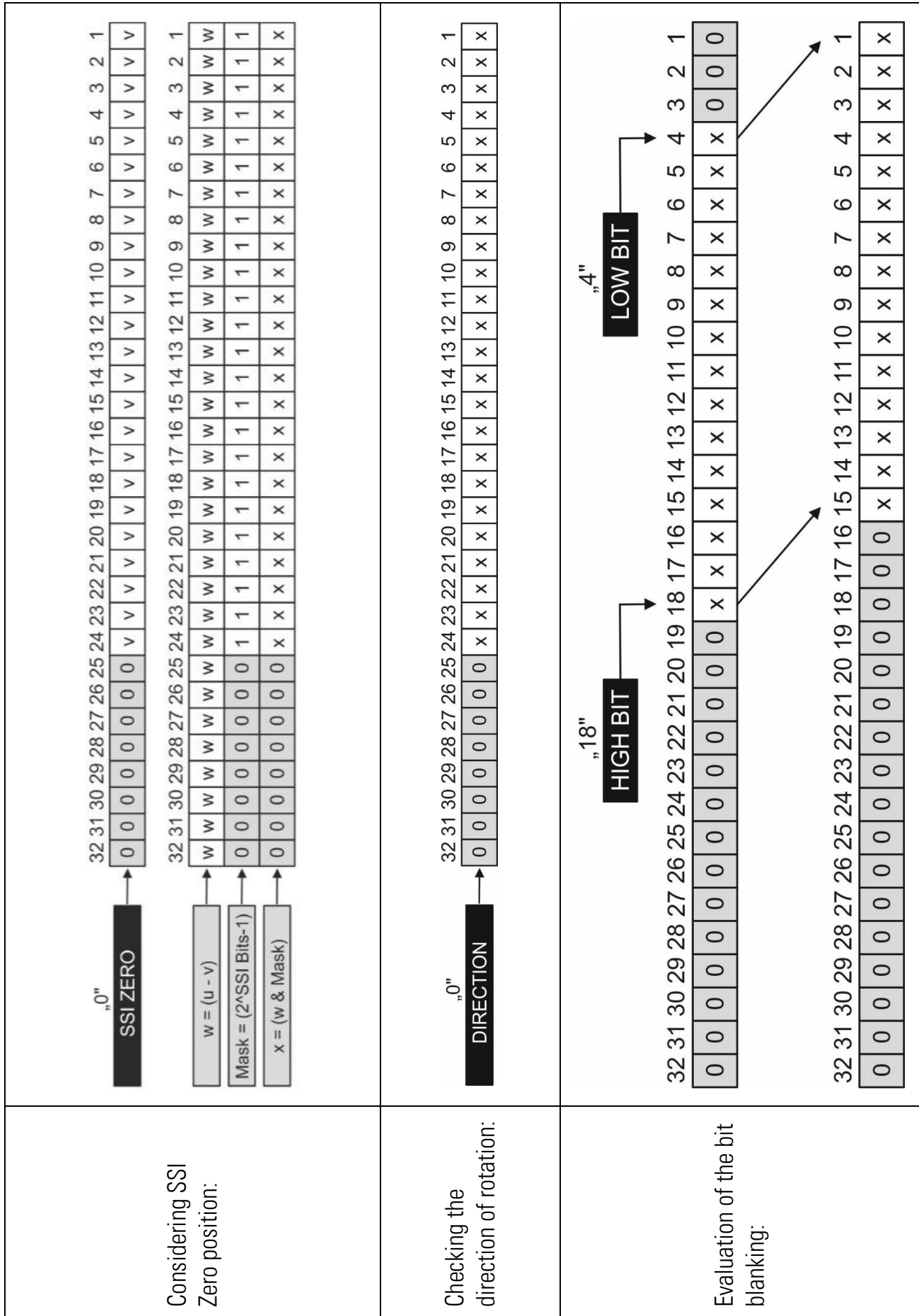

<p>Considering SSI Offset:</p>	
<p>Calculation Display Value:</p>	

6.6. Dimensions

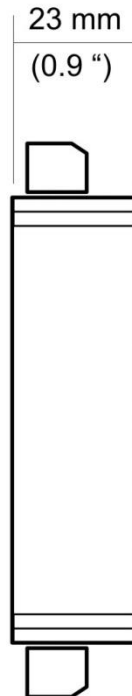
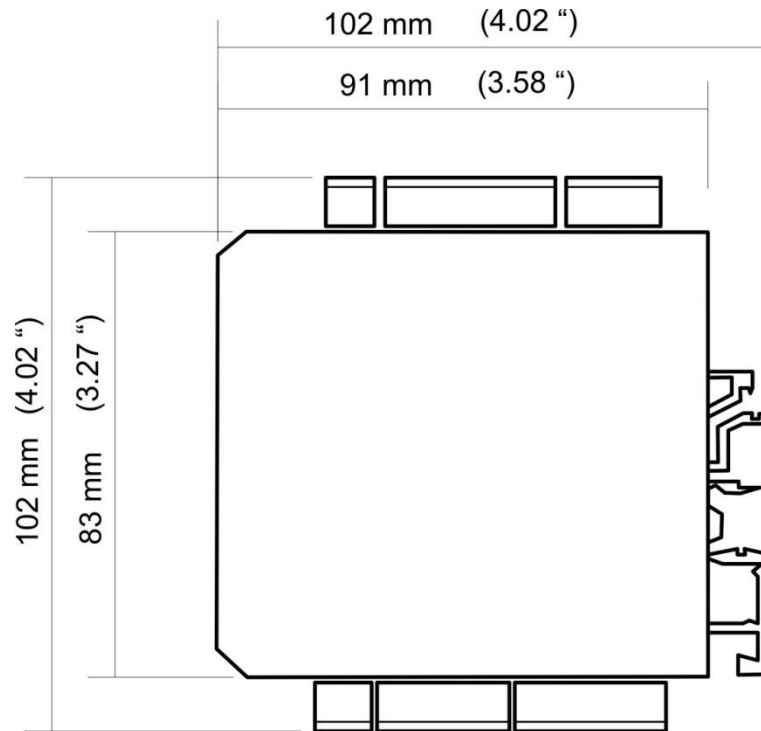

6.5. Technical Specifications:

Technical Specifications		
Connections:	Connector type:	screw terminal, 1.5 mm ² / AWG 16
Power supply (DC)::	Input voltage: Protection circuit: Consumption: Fuse protection:	18 ... 30 VDC reverse polarity protection approx. 50 mA (unloaded) extern: T 0.5 A
Encoder supply:	Output voltage: Output current:	5 VDC and 24 VDC (approx.1 V lower than the power supply) max. 250 mA
Incremental inputs:	Number of inputs: Configuration: RS422: HTL differential TTL/ HTL PNP / NPN: Load:	A, /A, B, /B RS422, TTL, HTL differential, HTL PNP oder HTL NPN max. 1 MHz (RS422 differential signal > 0,5 V) max. 500 kHz (HTL differential signal > 2 V) max. 250 kHz max. 6 mA / Ri > 5 kOhm / 10 pF
SSI interface:	Number (channels): Configuration: Format: Frequency: Resolution: Load:	Clock, /Clock, Data, /Data Master or Slave Binary or Gray code max. 1 MHz 10 ... 32 Bit Max. 3 mA / Ri > 10 kOhm / 10 pF
Control inputs:	Number of inputs: Format: Frequency: Load:	6 HTL, PNP (10 ... 30 V) max. 10 kHz max. 2 mA / Ri > 15 kOhm / 470 pF
Analog-output:	Configuration: Voltage output: Current output: Resolution: Accuracy: Reaction time:	current or voltage operation -10...+10 V (max. 2mA) 0/4 ... 20 mA (burden: max. 270 Ohm) 16 Bit ± 0,1 % < 1 ms
Control-Outputs:	Number of outputs: Format / level: Output current: Reaction time:	6 5 ... 30 V (depends on the Com+ voltage), PNP max. 200 mA < 1 ms
Serial interface:	Format: Baudrate:	RS232 oder RS485 9600, 19200 oder 38400 baud
Display:	LED:	red status LED
Housing:	Material: Mounting: Dimensions (w x h x d): Protection class: Weight:	Plastic housing 35 mm DIN rail (EN 60715) 23 x 102 x 102 mm IP20 approx. 100 g
Ambient temperature:	Operation: Storage:	-20°C ... +60°C (not condensing) -25°C ... +75°C (not condensing)
Conformity and standards:	EMC 2014/30/EU: RoHS (II) 2011/65/EU RoHS (III) 2015/863:	EN 61000-6-2, EN 61000-6-3, EN 61000-6-4, EN 61326-1 EN IEC 63000